

Electron Density and X-ray Diffraction

PROEFSCHRIFT

TER VERKRIJGING VAN DE GRAAD VAN DOCTOR IN
DE TECHNISCHE WETENSCHAPPEN AAN DE TECHNISCHE
HOGESCHOOL TWENTE TE ENSCHEDE OP GEZAG VAN
DE RECTOR MAGNIFICUS DR. IR. P.J. ZANDBERGEN,
HOGLERAAR IN DE ONDERAFDELING DER TOEGE-
PASTE WISKUNDE, VOOR EEN COMMISSIE UIT DE SENAAT
TE VERDEDIGEN OP DONDERDAG 7 OKTOBER 1971
DES NAMIDDAGS OM 4.00 UUR

door

SYBOLT HARKEMA

geboren te Noordeloos



1971

Type- en drukwerk Technische Hogeschool Twente

DIT PROEFSCHRIFT IS GOEDGEKEURD DOOR DE PROMOTOR

DR. D. FEIL

HOGLERAAR IN DE CHEMISCHE FYSICA

voor Hilda

Allen die in enige vorm hebben meegewerkt aan het totstandkomen van dit proefschrift betuig ik mijn hartelijke dank.

In het bijzonder dank ik mej. B.A. de Braal en de dames van de centrale correspondentiekamer voor de verzorging van het typewerk, de heer R.H. Arends voor het maken van de tekeningen en de reproductiedienst voor de zorg besteed aan het drukken van dit proefschrift.

De heer W. Song Loong ben ik zeer erkentelijk voor het feit dat hij de tekst van het proefschrift doorgelezen en waar nodig gecorrigeerd heeft.

CONTENTS

CHAPTER I	Introduction	9
1.	Outline of the present work	9
2.	Determination of electron density by means of X-ray analysis	10
3.	Review of previous work on the structure of salts of (thio)amides	12
4.	Literature	13
CHAPTER II	Determination of the crystal structure of uronium nitrate	15
1.	Preparation of the crystals	15
2.	Determination of the unit cell	15
3.	Measurement of intensities	16
4.	Determination of the structure	16
5.	Refinement of the structure	18
6.	Description of the structure	22
7.	Computer programs used	25
8.	Literature	27
CHAPTER III	Comparison of X-ray and neutron structure determination of uronium nitrate	28
1.	The neutron determination	28
2.	Reasons for differences between X-ray and neutron parameters	29
3.	Comparison of results	32
4.	Literature	40
CHAPTER IV	Semi-empirical quantumchemical calculations on uronium nitrate	41
1.	Introduction	41
2.	The C.N.D.O./2 method	43
3.	Calculations on the urea molecule	45
4.	Calculations on the uronium ion	47
5.	Nitrate ion	49
6.	Influence of hydrogen bonding on bond lengths	49
7.	Literature	54
CHAPTER V	Calculations with different form factor models	55
1.	Introduction	55
2.	Basis functions	56
3.	Calculation of scattering factors from Slater orbitals	57
4.	Calculation of scattering factors from Gauss orbitals	63
5.	Determination of the number of valence electrons	67
6.	Calculations with scattering factors based on aspherical electron densities	70
7.	Literature	74

CHAPTER I

INTRODUCTION

1.1 Outline of the present work

One of the main tasks of quantum-chemistry is to calculate accurate wave functions for atomic and molecular systems. When the exact wave function for a system is known, all observable quantities of that system can be computed from the wave function. Wave functions computed are tested by comparing calculated properties with experimental ones. Examples of quantities frequently used for this purpose are: heat of formation, spectral transition energies, dipole moment and ionization energy. Some of these quantities, however, do not give a good test of the computed wave function. The same value of the dipole moment for instance can be computed from a number of wave functions, some of which give a rather poor agreement with the exact wave function. For this reason more direct tests for approximate wave functions are desirable. The observable quantity most directly connected with the wave function, (which is not an observable), is the electron density. The relation between the electron density (ρ)-and the wave function (ψ) is given by:

$$\rho(\mathbf{r}) = \psi^*(\mathbf{r}) \psi(\mathbf{r}) \quad (1.1)$$

In this equation ψ^* means the complex conjugate of ψ .

A method by which the electron density can be determined is X-ray diffraction. The electron density at a point in the unit cell of a single-crystal can be described by:

$$\rho(\mathbf{r}) = V^{-1} \sum_{\mathbf{h}} \mathbf{A}_{\mathbf{h}} \exp(-2\pi i \mathbf{h} \cdot \mathbf{r}) \quad (1.2)$$

in which V is the volume of the unit cell and $\mathbf{A}_{\mathbf{h}}$ is a complex constant associated with the reciprocal lattice vector \mathbf{h} . The summation has to be carried out for all possible reciprocal lattice vectors.

According to the theory of X-ray diffraction (James, 1948, chapter 7) the constants $\mathbf{A}_{\mathbf{h}}$ of eq. (1.2) are equal to the structure factors $F_{\mathbf{h}}$ of the X-ray reflexions from the reflecting planes ($h_1 h_2 h_3$).

$$A_{\mathbf{h}} = F_{\mathbf{h}} \quad (1.3)$$

$$\mathbf{h} = h_1 \mathbf{a}^* + h_2 \mathbf{b}^* + h_3 \mathbf{c}^* \quad (1.4)$$

\mathbf{a}^* , \mathbf{b}^* , and \mathbf{c}^* are the basis vectors of the reciprocal unit cell.

The absolute value of the structure factor is a quantity measurable by X-ray diffraction. The phase of the structure factor (or its sign in case of a centrosymmetric structure) cannot be determined directly from X-ray measurements. The determination of phase angles constitutes the main problem in X-ray crystallography.

When the phase problem for a given structure has been solved, equations (1.2) and (1.3) give the relation between the electron density and experimental quantities.

Until recently X-ray single-crystal diffractometry has been used almost exclusively for the determination of structural parameters, such as cell dimensions and atomic positions. In the last decade, however, it has been realised that valuable information on electron densities may be obtained from diffraction experiments. One of the most interesting problems which can be studied by X-ray diffraction is the redistribution of charge which takes place when atoms combine to form a molecule. A short review of the methods used in the determination of electron distributions by X-rays and the difficulties associated with them is given in section 1.2.

In this thesis mainly work done on uronium nitrate will be described. Uronium nitrate was chosen since it is a stable compound composed of relatively small groups of light atoms. Furthermore an interesting chemical question related to the site of protonation in salts of urea, could be solved by X-ray methods. These chemical aspects and previous work on the structures of salts of urea will be reviewed in section 1.3.

1.2 Determination of electron density by means of X-ray analysis.

The accuracy of X-ray structure determinations has increased considerably during the last decades especially by the introduction of single-crystal diffractometers for the measurement of intensities. Evidence for this increase is the fact that determination and refinement of the positions of hydrogen atoms (even in the presence of heavy atoms) has become more or less a standard routine in X-ray crystallography.

The increasing accuracy has also raised the important question whether the model commonly used in X-ray crystallography is appropriate to describe the details of the diffraction experiments. The normal model used for

calculating scattering factors consists of spherical atoms in their ground state (James, 1962). Scattering factors based on this model are used almost exclusively in X-ray crystallography. As the electron density in a molecule is not simply the sum of the electron densities of the constituent atoms (Ransil and Sinai, 1967) one expects that better models are needed to describe the details of accurate diffraction experiments. These better models should allow for the redistribution in electron density which occurs when chemical bonds are formed.

Several investigators have calculated atomic scattering factors based on atoms in their valence state (McWeeny, 1951; Dawson, 1964). Scattering factors computed in this way can be based on aspherical electron densities of hybridised states. The application of these valence-state scattering factors to uronium nitrate will be described in chapter V. The semi-empirical quantum-chemical calculations and the wave functions necessary for the construction of the atomic scattering factors will be given in chapter IV.

Methods for taking into account the scattering of the so-called overlap densities have been given in the literature (McWeeny, 1952, 1953; Stewart, 1969). Calculations along these lines will be reported in chapter V.

Computations of X-ray scattering factors from ab initio molecular wave functions have been used in a few cases (Groenewegen and Feil, 1969; Jones and Lipscomb, 1970). A first attempt to calculate elements of the charge-bond order matrix from X-ray diffraction experiments is given by Coppens et al. (1970).

Studies to visualize the distribution of bonding electron density from X-ray experiments are difficult, because of the fact that there is a great deal of correlation between the effect one wishes to determine and the positional and thermal parameters of the different atoms. The effect of bonding electrons is compensated by an 'adjustment' of thermal and positional parameters. It is a well-known fact that lengths of bonds involving hydrogen are always too short when determined by X-ray diffraction (Jones and Lipscomb, 1970). Thermal parameters determined for hydrogen atoms, using scattering factors computed for the ground state, have little physical significance (Stewart et al. 1965).

Despite these problems a number of investigations has shown that in accurate X-ray diffraction analysis the effect of chemical bonding is not negligible. A survey of the results is given by O'Connell et al. (1966).

In view of these difficulties another method for determination of positional and thermal parameters is needed. For this purpose elastic neutron diffraction can be used. As the scattering of neutrons takes place at the atomic nucleus (Bacon, 1955) this technique gives accurate data on position and motion of the atomic nucleus. Including parameters obtained by neutron diffraction in X-ray experiments can prevent a great deal of the correlation problems described above.

A number of investigations on the same compound by neutron and X-ray diffraction has been carried out. Examples are given by Coppens et al. (1969) and Duckworth et al. (1970). The results of these investigations indicate clearly that the redistribution of charge in a molecule as a result of chemical bonding is a measurable effect.

In the case of uronium nitrate a neutron diffraction study was made independently of our work. The results of this work by Worsham and Busing (1969) will be compared with our work in chapter III.

1.3 Review of previous work on the structure of salts of (thio)amides

The site of protonation in (thio)amide cations has been disputed in the chemical literature for a long time. The two possible structures for the protonated (thio) urea cation ((thio) uronium ion) are given in fig 1.1

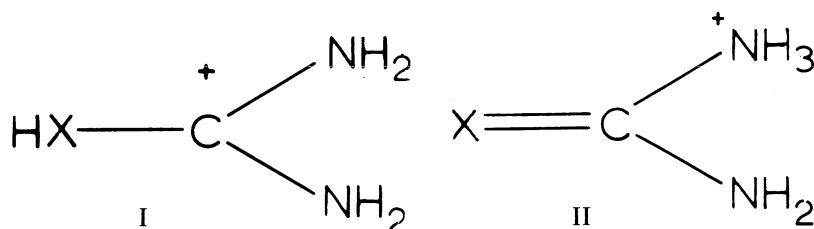

Fig. 1.1 - Two possible structures for the (thio)uronium ion

On theoretical grounds structure I is preferred, owing to its greater resonance energy. A review of the literature until 1961 is given by Jones and Katritzky (1961). More recent investigations have been summarized by Stewart and Siddall (1970).

The *infrared spectra* of (thio)urea and (thio)uronium nitrate have been the subject of a number of studies. From the spectrum of uronium nitrate Davies and Hopkins (1957) concluded that the acidic proton was attached to one of the NH_2 -groups.

The investigation of Spinner (1959) gave the same results, although his conclusions did not agree with that of Davies and Hopkins in all points. Their arguments were mainly based on the absence of a clearly identifiable OH-bond in the 3μ region. The conclusions of Janssen (1961) and Kutzelnigg and Mecke (1961a, 1961b) are in contradiction with the above-mentioned results. They conclude that the proton is attached to the oxygen (sulphur) atom. The absence of the OH-absorption in the normal position is explained by the presence of strong hydrogen bonds.

From *nuclear magnetic resonance* experiments Birchall and Gillespie (1963) conclude that the protonation of thiourea in fluorosulphuric acid takes place at the sulphur atom. For urea no conclusion could be drawn, the proton exchange being too fast, even at -80°C . Evidence is given that protonation of other amides takes place at the oxygen atom. The same results as to the site of protonation are given by the experiments of Redpath and Smith (1962) on polycrystalline samples of urea and thiourea salts.

X-ray structure determinations of (thio)urea salts have been carried out on a few salts of urea. The results of structure determinations of urea phosphate (Sundera-Rao et al. 1957) and N-methyluronium nitrate (Bryden, 1957) although of limited accuracy indicated that the proton becomes attached to the oxygen atom. The structure determination of urea oxalic acid (Harkema et al. 1971) indicated that this compound does not exist as uronium and oxalate ions, but as urea and oxalic acid molecules.

In view of the discrepancies described above, a number of structure determinations of urea and thiourea compounds was started in this laboratory. The determinations include: thiouronium nitrate (Feil and Song Loong, 1968); uronium nitrate (Harkema and Feil, 1969); N-methyluronium nitrate (Selman and Harkema, 1971) and urea oxalic acid (Harkema et al. 1971). This thesis will describe mainly work done on uronium nitrate. The determination of the structure is described in chapter II.

1.4 Literature

- BACON, G.E. (1955). Neutron Diffraction, *Oxford University Press*.
 BIRCHALL, T and GILLESPIE, R.J. (1963). *Can. Journ. of Chem.* **41**, 2642.
 BRYDEN, J.H. (1957). *Acta Cryst.* **10**, 714.
 COPPENS, P., SABINE, T.M., DELAPLANE, R.G. and IBERS, J.A. (1969), *Acta Cryst.* **B25**, 2451.
 COPPENS, P., CSONKA, L., WILLOUGHBY, T.V. (1970). *Science* **167**, 1126.
 DAVIES, V.M. and HOPKINS, L. (1957). *Trans. Farad. Soc.* **53**, 1563.
 DAWSON, B. (1964). *Acta Cryst.* **17**, 997.
 DUCKWORTH, J.A.K., WILLIS, B.T.H. and PAWLEY, G.S. (1970). *Acta Cryst.* **A26**, 263.
 FEIL, D. and SONG LOONG, W. (1968). *Acta Cryst.* **B24**, 1334.
 GROENEWEGEN, P.P.M. and FEIL, D. (1969). *Acta Cryst.* **A25**, 444.
 HARKEMA, S. and FEIL, D. (1969) *Acta Cryst.* **B25**, 589.
 HARKEMA, S., BATS, J.W., WEYENBERG, A.M., and FEIL, D. (1971) *Acta Cryst.* to be published.
 JAMES, R.W. (1948). The Optical Principles of the Diffraction of X-rays, Chapter III. - London: *Bell*.
 JANSSEN, M.J. (1961). *Spektrochim. Acta* **17**, 475.
 JONES, D.S. and LIPSCOMB, W.N. (1970). *Acta Cryst.* **A26**, 196.
 JONES, R.A.Y. and KATRIZKY, A.R. (1961). *Chem. and Ind.* 722.
 KUTZELNIGG, W. and MECKE, R. (1961a). *Ber.* **94**, 1706.
 KUTZELNIGG, W. and MECKE, R. (1961b). *Spectr. Acta* **17**, 530.

- McWEENY, R. (1951). *Acta Cryst.* **4**, 513.
McWEENY, R. (1952). *Acta Cryst.* **5**, 463.
McWEENY, R. (1953). *Acta Cryst.* **6**, 631.
O'CONNELL, A.M., RAE, A.I.M. and MASLEN, E.N. (1966). *Acta Cryst.* **21**, 208.
RANSIL, B.J. and SINAI, J.J. (1967). *J. Chem. Phys.* **46**, 4050.
REDPATH, C.R. and SMITH, J.A.S. (1962). *Trans. Farad. Soc.* **58**, 462.
SELMAN, W.F. and HARKEMA, S. (1971). Progress Report, Chem. Phys. Lab., Twente University of Technology.
SPINNER, E. (1959). *Spektrochim Acta* **15**, 95.
STEWART, R.F. (1969). *J. Chem. Phys.* **51**, 4569.
STEWART, R.F., DAVIDSON, E.R. and SIMPSON, W.T. (1965). *J. Chem. Phys.* **42**, 3175.
STEWART, W.E. and SIDDALL, T.H. (1970). *Chem. Rev.* **70**, 517.
SUNDERA-RAO, R.V.G., TURLEY, J.W. and PEPINSKY, R. (1957). *Acta Cryst.* **10**, 435.
WORSHAM, J.E. and BUSING, W.R. (1969). *Acta Cryst.* **B25**, 572.

CHAPTER II

DETERMINATION OF THE CRYSTAL STRUCTURE
OF URONIUM NITRATE

2.1 Preparation of the crystals.

Uronium nitrate ($\text{CO}(\text{NH}_2)_2 \cdot \text{H} \cdot \text{NO}_3$) was prepared by adding nitric acid to a concentrated solution of urea in water. Uronium nitrate, which is sparingly soluble in water, is precipitated as small crystals. Attempts to recrystallize uronium nitrate from water gave crystals which were almost invariably twinned. The crystals and their twinning behaviour have been described by Barker (1911). Attempts to separate the twin individuals were not successful. The crystals have an almost perfect (mica like) cleavage plane. Cutting of the crystals gives rise to severe deformation which makes the crystals unsuitable for X-ray analysis experiments. The percentage of twinned crystals is much less when uronium nitrate is crystallized from methanol. Crystals obtained in this way have been used in the X-ray diffraction experiments. The habit of the crystals is prismatic, the zone axis being [100] or [010]. The cleavage plane is (001).

2.2 Determination of the unit cell

Rotation and Weissenberg photographs showed the unit cell to be monoclinic. The unit cell parameters as determined on the single-crystal diffractometer are:

$$\begin{aligned} a: & 9.535 (7) \text{ \AA} \\ b: & 8.198 (5) \text{ \AA} \\ c: & 7.500 (6) \text{ \AA} \\ \beta: & 124.22 \pm .05^\circ \end{aligned}$$

The unit cell dimensions found are in fair agreement with the values given by Lonsdale (1940). The systematic absences are $h0l$ if $l = 2n + 1$ and $0k0$ if $k = 2n + 1$. By these absences the space group is uniquely defined as the centrosymmetric space group $P2_1/c$ (no. 14, International Tables). Apart from the systematic absences the reflexions $0kl$ with $k = 2n + 1$ are extremely weak. With four molecules in the unit cell the calculated density is 1.68 g.cm^{-3} . The observed density is 1.69 g.cm^{-3} (Lonsdale, 1940).

2.3 Measurement of intensities

A small crystal (maximum dimension 0.1 mm) was mounted in a Lindemann capillary with the unique crystal axis parallel to the axis of the goniometer head. Intensities were measured on a Nonius automatic three circle diffractometer equipped with a scintillation counter and pulse height discriminator. The radiation used was Zr filtered Mo K_{α} radiation ($\lambda = .7093\text{\AA}$). Intensities were determined using the $\theta-2\theta$ scanning technique. Background measurements were made during half the scanning time on both sides of the θ scanning region. The reflexions 400 and 004 were chosen as standard reflexions. After every twenty reflexions one of the standard reflexions was measured. While measuring intensities no systematic trend in the intensities of the standard reflexions could be detected. The standard deviation in the intensities of the standard reflexions was approximately 1%. The differences in intensities of reflexions determined more than once were generally within the deviations predicted by counting statistics. All reflexions with $\theta < 25^{\circ}$ ($\sin \theta/\lambda < .6$) were measured at room temperature ($21 \pm 1^{\circ}\text{C}$). The total number of reflexions measurable in this range was 906, of which 253 had an intensity less than twice the standard deviation from counting statistics. The latter reflexions will be called unobserved reflexions in subsequent sections. As the number of unobserved reflexions rapidly increased with increasing θ , no intensity measurements were made at $\theta > 25^{\circ}$. In view of the small dimensions of the crystal and the low value of the absorption coefficient ($\mu_r = .02$) no correction for absorption was applied. Intensities have also been measured with Ni-filtered Cu K_{α} radiation. The number of reflexions measured was 628 of which 26 were below the threshold value for an observed reflexion. These intensities have been used in the first stages of the structure determination.

2.4 Determination of the structure

The crystal structure of a compound is described by three positional parameters for each atom in the asymmetric unit. In addition to these positional parameters in general six parameters are needed to give a description of the anisotropic thermal motion of the atoms in the asymmetric unit. These six parameters determine the magnitude and direction of the vibration ellipsoid which gives the root mean square displacement of the atoms in the different directions. In the case of isotropic thermal motion one thermal parameter is sufficient. A crystal structure is considered solved when the parameters, which can be determined by X-rays, are known.

In order to elucidate the crystal structure for a given compound crystallizing in a centrosymmetric space group one has to solve the sign problem (eq. 1.3). To attack this problem in the case of a structure consisting of atoms of nearly the same atomic number two methods are generally employed:

- (1) **Patterson method.** It is possible to calculate from the absolute values of the X-ray structure factors a so-called Patterson function.

$$P(\mathbf{u}) = \sum_{\mathbf{h}} |F_{\mathbf{h}}|^2 \exp(2\pi i \mathbf{h} \cdot \mathbf{u}) \quad (2.1)$$

According to the theory of X-ray diffraction (Stout and Jensen, 1968, chapter II) the Patterson function is equal to the convolution:

$$P(\mathbf{u}) = \int \rho(\mathbf{r})\rho(\mathbf{r}+\mathbf{u})d\mathbf{r} \quad (2.2)$$

In practice this means that the Patterson function contains all interatomic vectors. The problem is the deconvolution of the Patterson function, which results in the position of the atoms.

- (2) **Direct methods.** These methods which are based on statistical relations between the absolute values of the structure factors, are able to give the signs of the strongest reflexions. (Woolfson, 1961). With these strong reflexions a Fourier synthesis can be made from which positions of the atoms can be extracted.

A three dimensional Patterson synthesis was calculated. All peaks occurred at $z/c = .0$ and $z/c = .5$ indicating that uronium nitrate has a layered structure with layers parallel to the xy plane (layer spacing 3.10 \AA). From the fact that the $0kl$ reflexions for $k = 2n + 1$ are very weak it can be concluded that the z/c coordinates of all atoms in the unit cell should be approximately .25 and .75.

The geometrical structure factor (International Tables for X-ray Crystallography, part I) for the $0kl$ reflexions of the space $P2_1/c$ is:

$$A = \cos [2\pi(lz/c + (k + l)/4)] \cos [2\pi(ky/b - (k + l)/4)] \quad (2.3)$$

In the case that the z/c coordinates of all atoms are near .25 or .75 this expression reduces to:

$$A = \cos [\pi(k + 2l)/2] \cos [2\pi(ky/b - (k + l)/4)] \quad (2.4)$$

When $k = 2n + 1$ the expression (2.4) is zero.

It was assumed that the structure consisted of uronium and nitrate ions in the 'facing' arrangement, as found in N-methyluronium nitrate (Bryden, 1957) and thiuronium nitrate (Feil and Song Loong, 1968). From sharpened Patterson syntheses (point atoms at rest) a number of orientations for the

uronium nitrate group was found. One of these trial structures gave rather good agreement with experiment using only low-order reflexions. In the meantime attempts to solve the structure by means of direct methods were made. The method applied manually to the $hk0$ projection was the method of Zachariasen (1952) as described by Woolfson (1961). The result of this sign-determining procedure was that the signs of all strong reflexions except one agreed with the signs calculated from the model found by the Patterson method. Calculations up to this point were done using one atomic form factor (that of nitrogen) for all heavy atoms. The difficulty arising now was to distinguish the urea and nitrate groups, which have almost the same scattering power for X-rays. Assuming the facing arrangement of uronium and nitrate ions suggested two possibilities, one of which gave a slightly better comparison with experiment. Ultimately the positions of the hydrogen atoms confirmed the correctness of the structure chosen.

2.5 Refinement of the structure

The **Cu data** were refined first. The weight for each reflexion was taken to be $w = 1/\sigma^2$, where σ is the estimated standard deviation of the structure factor. The σ was taken as $\sigma = 2S + .01 |F_0|$, where S is the standard deviation due to counting statistics and F_0 is the observed structure factor. The function minimized was $w(|F_0| - s|F_c|)^2$ where F_c is the calculated structure factor and s is a scaling factor.

Refinement of the positions and isotropic temperature factors of the heavy atoms resulted in an R-factor of 15.4%.^{*} A different Fourier synthesis made at this stage, clearly revealed hydrogen atoms. Next a few cycles of refinement were done with the temperature factors of the heavy atoms in anisotropic form. The R-factor dropped to 7.7%. A difference Fourier synthesis made after this refinement is shown in figure 2.1. The map gives the location of all five hydrogen atoms. The acidic proton is attached to the urea oxygen. Therefore the name uronium nitrate is the correct one for this substance. Inclusion of the hydrogen atoms and some cycles of refinement gave a final R-value of 4.8%. Parameters refined were: positions and isotropic temperature factors of the hydrogen atoms, positions and anisotropic temperature factors of the heavy atoms.

^{*}):

The R-factor is defined as $\sum (|F_0| - |F_c|) / \sum |F_0|$. Another measure of fit the so-called weighted R-factor which will be used, is given by $R_w = (\sum w (|F_0| - s|F_c|)^2 / \sum w |F_0|^2)^{1/2}$.

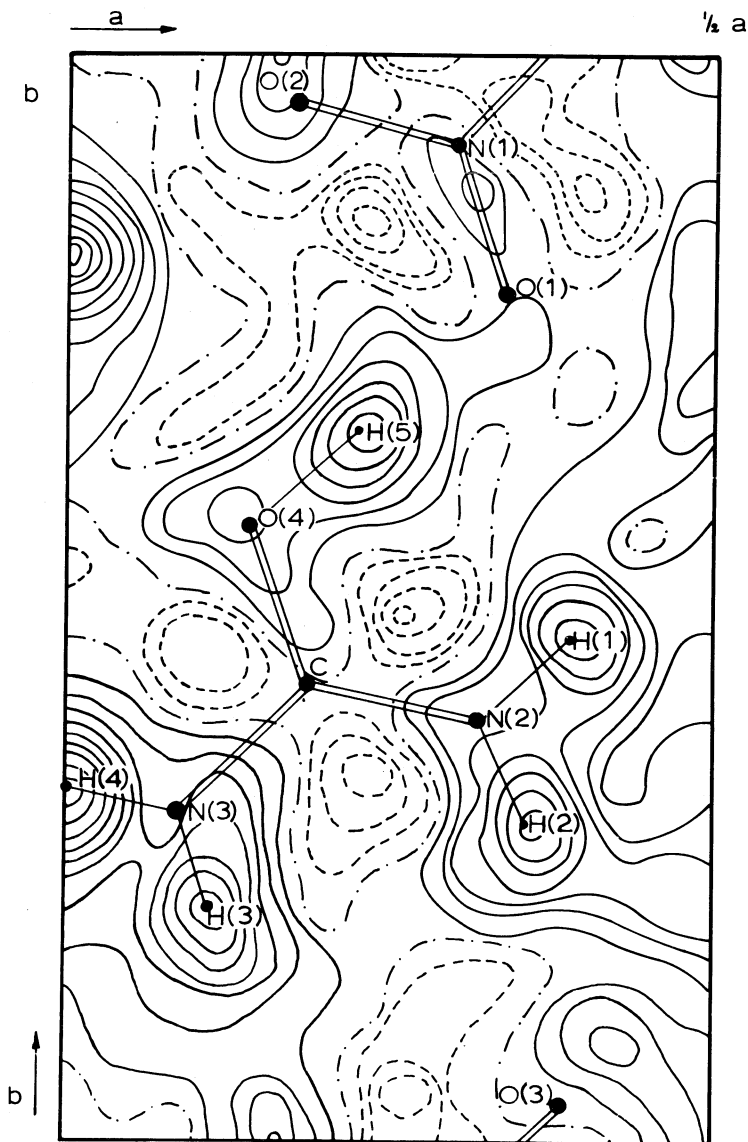

Difference Fourier synthesis ($z/c = .25$) showing the positions of the hydrogen atoms in uronium nitrate.

Next the **Mo** data were refined. The temperature and positional parameters obtained from the refinement of the Cu-data were taken as starting point for the refinement. After a few cycles of refinement the R-factor was 6.1% ($R_w = 4.1\%$). During the refinement the very strong $00l$ reflexions were

omitted, since they are expected to be affected by extinction. The R-factor using the observed reflexions only was 4.1% ($R_w = 4.0\%$). The atomic scattering factors used in the refinement were those calculated from accurate atomic wave functions (Chapter V, tables 5.1, 5.2, and 5.3) except for the scattering factors of the hydrogen atom. The scattering factor for the last element was taken from Stewart, Davidson and Simpson (1965). In this scattering factor some effects of bonding are taken care of. The resulting positional and atomic parameters are given in table 2.1 and 2.2 respectively. As is easily verified from the tables there is no significant difference between the results of the two different data sets (observed + unobserved reflexions, ob-

	x/a		y/b		z/c	
	Mo 1	Mo 2	Mo 1	Mo 2	Mo 1	Mo 2
C	.1981(3)	.1981(3)	.4105(3)	.4105(2)	.2556(5)	.2558(4)
N(1)	.3112	.3112	.9170	.9171	.2542	.2542
N(2)	.3334	.3334	.3766	.3767	.2605	.2605
N(3)	.1010	.1010	.2963	.2963	.2537	.2537
O(1)	.3521	.3521	.7724	.7723	.2493	.2493
O(2)	.1871	.1871	.9459	.9460	.2602	.2602
O(3)	.3969	.3969	.0297	.0297	.2516	.2517
O(4)	.1497	.1497	.5614	.5613	.2483	.2484
H(1)	.402 (4)	.402 (4)	.451 (4)	.451 (4)	.259 (6)	.259 (5)
H(2)	.372	.371	.266	.266	.278	.277
H(3)	.134	.133	.177	.177	.246	.245
H(4)	-.009	-.009	.324	.325	.243	.243
H(5)	.234	.233	.649	.648	.258	.257

Table 2.1

Final positional parameters for uronium nitrate. The columns Mo 1 are the results of the refinement of observed reflexions. Parameters of the refinement with all reflexions are given in the columns marked Mo 2. The standard deviation given is applicable to all heavy or light atoms in one column.

served reflexions only). Therefore the rest of the calculations was mainly performed with the observed reflexions, to give a saving in computer time. A list of observed and calculated structure factors is given in Appendix I.

From the correlation matrix produced by the full matrix least squares program a rather high correlation (.6) was found between the x and z coordinate of the same atom, due to the fact that the a and c axes are not perpendicular to each other.

	U ₁₁		U ₂₂		U ₃₃		U ₁₂		U ₁₃		U ₂₃	
	Mo 1	Mo 2	Mo 1	Mo 2	Mo 1	Mo 2	Mo 1	Mo 2	Mo 1	Mo 2	Mo 1	Mo 2
C	.034 (1)	.035 (1)	.021 (1)	.021 (1)	.037 (2)	.037 (2)	.000 (1)	.000 (1)	.021 (2)	.021 (1)	.002 (1)	.002 (1)
N(1)	.039	.039	.023	.023	.052	.052	.003	.002	.029	.029	.001	.001
N(2)	.039	.039	.027	.027	.065	.065	-.001	-.001	.037	.037	.001	.000
N(3)	.039	.039	.022	.022	.066	.066	-.003	-.002	.035	.035	.001	.001
O(1)	.058	.058	.016	.016	.094	.093	.004	.004	.054	.054	.001	.001
O(2)	.049	.049	.031	.031	.102	.102	.002	.001	.058	.058	.000	.000
O(3)	.048	.048	.021	.021	.076	.076	-.005	-.005	.044	.044	.001	.001
O(4)	.045	.045	.018	.018	.072	.072	.004	.004	.039	.038	.002	.002
H(1)	4.9 (10)	5.2 (8)										
H(2)	4.4	4.3										
H(3)	7.2	7.0										
H(4)	5.2	5.3										
H(5)	8.6	8.3										

Table 2.2

Vibration parameters. The temperature factor for the heavy atoms was $\exp -2\pi^2(h^2 a^{*2} U_{11} + 2hka^*b^*U_{12} + \dots)$. The temperature factor for the hydrogen atoms was $\exp -(B \sin^2 \theta / \lambda^2)$. The meaning of the different columns is given in table 2.1.

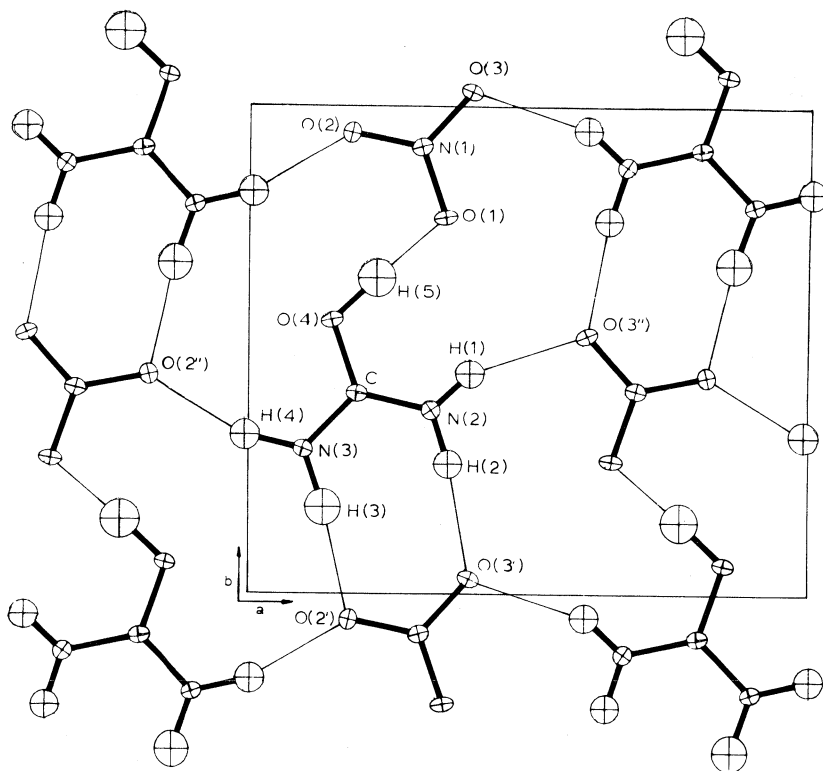

Figure 2.2

One layer of the uronium nitrate structure ($z/c = .25$) giving the positions and thermal vibration ellipsoids of the different atoms. The vibration ellipsoids are scaled to include 50% probability. Hydrogen bonds are denoted by a thin line.

2.6 Description of the structure

The structure of uronium nitrate as determined by X-ray diffraction is shown in figure 2.2. The figure, which gives a layer of the structure, clearly reveals the fact that in the crystal a two dimensional hydrogen bonding network is present. This two dimensional network explains the presence of the perfect cleavage plane. The bonding between different layers is mostly due to

the relatively weak van der Waals forces.

The structure may be considered built from units of uronium nitrate ions in the facing arrangement. These units concatenated to an infinite chain by rather short O(4) – H(5) O(1) bonds. Bonding between different chains in the same plane (which are related to each other by means of a screw axis) is effected by hydrogen bonding in which the remaining two hydrogen atoms of the uronium nitrate ions are involved. All hydrogen atoms in the structure are part of a hydrogen bond. The X–H . . . Y bonds found are nearly straight and the hydrogen atoms are directed towards the regions in which the lone pair electrons of the hydrogen bond accepting atoms are located. The last two facts are conditions for getting a stable hydrogen bond. Bond distances and angles found in urea nitrate are given in table 2.3 and table 2.4 respectively. The uronium and nitrate ions are nearly planar. The distances of the atoms to the best planes fitted to the positions of the heavy atoms are given in table 2.5.

N(1)–O(1)	1.256(4)	N(2)–H(1)	.90(5)	N(2) .. O(3)	2.919(5)
N(1)–O(2)	1.233	N(2)–H(2)	.96	N(2) .. O(3')	2.907
N(1)–O(3)	1.242	N(3)–H(3)	1.03	N(3) .. O(2')	2.981
C –N(2)	1.301	N(3)–H(4)	1.04	N(3) .. O(2'')	2.954
C –N(3)	1.312	O(4)–H(5)	1.04	O(1) .. O(4)	2.588
C –O(4)	1.311				

Table 2.3: Bond distances (\AA) in uronium nitrate.

O(1) –N(1) –O(2)	120.2(3)	C –N(2) –H(1)	125(4)
O(1) –N(1) –O(3)	119.0	C –N(2) –H(2)	120
O(2) –N(1) –O(3)	120.8	C –N(3) –H(3)	116
O(4) –C –N(2)	121.5	C –N(3) –H(4)	121
O(4) –C –N(3)	116.3	C –O(4) –H(5)	114
N(2) –C –N(3)	122.2	H(1) –N(2) –H(2)	115(6)
		H(3) –N(3) –H(4)	122

Table 2.4: Bond angles ($^{\circ}$).

nitrate ion		uronium ion			
N(1)	.004	C	.006	H(1)	-.03
O(1)	-.001	N(2)	-.002	H(2)	.10
O(2)	-.001	N(3)	-.002	H(3)	-.06
O(3)	-.001	O(4)	-.002	H(4)	-.02
				H(5)	.04

Table 2.5.

Distances (\AA) of the atoms to the best planes fitted to the positions of the heavy atoms of the uronium and the nitrate ions.

All *bond angles* found in the structure are close to 120° as may be expected for planar structures in which the carbon and nitrogen atoms are sp^2 hybridised. A significant difference in the two N–C–O angles of the uronium ion is found. A similar distortion is also found in thiouronium nitrate (Feil and Song Loong, 1968) and N–methyluronium nitrate (Selman and Harkema, 1971). In urea–oxalic acid which consists of strongly hydrogen bonded urea and oxalic acid molecules the distortion is much less pronounced (Harkema, Bats, Weyenberg and Feil, 1971). The differences in bond angles are therefore caused by the protonation of the urea molecule.

Considering *bond lengths*, it is found that the C–O and C–N distances are significantly different from the ones found in urea: C–O: 1.243(6), C–N: 1.351(7) (Worsham, Levy and Peterson, 1957). A simple explanation of these facts may be given by the following arguments based on valence bond theory. The principal resonance structures of the urea molecule are given in figure 2.3. Structure I is the predominant one, while structures II and III (which have equal weights) occur to a lesser extent.

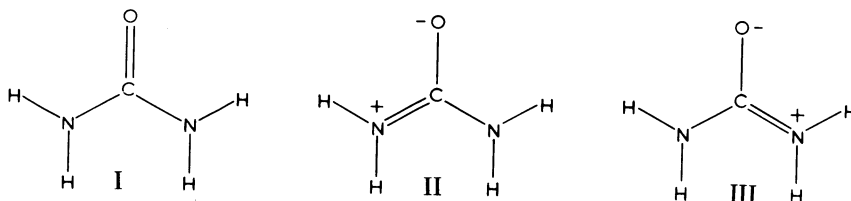

Figure 2.3

Three principal resonance structures for the urea molecule.

Protonation of urea (at the oxygen atom) will stabilize the structures II and III and give rise to a shortening of the C–N bond and a lengthening of the C–O bond as found experimentally.

In the nitrate ion one of the N–O distances is significantly longer than the other two. When a correction for thermal motion* (Cruickshank, 1961) is made, it is found that the differences described still exist and that their order of magnitude is not altered. The longer bond length can be explained by the strong hydrogen bond in which O(1) is involved. A detailed discussion of the geometric details will be given in Chapter IV by means of quantum-chemical calculations.

Thermal parameters have been transformed to a system with three perpendicular axes: the crystallographic **a**, **b**, and **c*** axes. The third axis is perpendicular to the planes in which the molecules are contained. The principal axes of the thermal ellipsoids have been determined. The root mean square displacement ($\langle U^2 \rangle^{1/2}$, where *U* is the displacement of an atom in the direction under consideration) along the principal axes are given in table 2.6 (see page 26). The table also contains the direction cosines of the angles between the principal axes of the thermal ellipsoids and the three perpendicular unit vectors. From the values for the root mean square displacements and the direction cosines given in the table it can easily be verified that the largest thermal motion is found perpendicular to the plane containing the molecules. This behaviour can be explained by the fact that bonding forces within the molecular plane are much stronger than between the layers of molecules. The projections of the principal axes of the thermal ellipsoids of the different atoms are also shown in figure 2.2.

2.7 Computer programs used

During the work described in this chapter the following computer programs have been used.

- NONA** This program (Song Loong, 1967) calculates the setting angles for the automatic diffractometer. The values of the different angles are written on a disc and used in the following program.
- NIT** prepares the input tape for the diffractometer (Harkema, 1968).

* Drs. A.F.J. Ruysink (Laboratorium voor Structuurchemie, Groningen) kindly performed the calculations of the thermal motion correction.

	axis 1				axis 2				axis 3			
	1	2	3	4	1	2	3	4	1	2	3	4
C	.141	-.130	-.982	.137	.184	.987	-.116	.108	.193	-.091	.149	.985
N(1)	.148	.237	-.971	.020	.181	-.971	-.237	.016	.228	.011	.023	.999
N(2)	.160	-.752	-.659	.017	.167	-.659	.752	.003	.256	.014	.009	.999
N(3)	.145	-.314	-.950	.001	.178	-.946	-.313	.082	.258	-.077	.026	.997
O(1)	.123	.154	-.988	.007	.200	-.987	-.154	.038	.305	.037	.013	.999
O(2)	.153	-.979	.206	.008	.175	-.206	-.979	.007	.319	.010	.005	1.000
O(3)	.133	-.403	-.915	.022	.186	-.914	.404	.033	.275	.039	.007	.999
O(4)	.132	.198	-.979	.047	.189	.978	.201	.057	.269	-.065	.034	.997

Table 2.6

Root mean square displacements along the principal axes of the thermal vibration ellipsoids and the direction cosines of the principal axes. Column 1: root mean square displacements. Columns 2, 3, 4: cosines of the angles between the principal axes and the a , b , and c^* unit cell vectors.

- NOT This program (Harkema, 1968) is used to process the output tape of the diffractometer. Intensities and their standard deviations are calculated. Reflexions are divided into observed, non-significant and standard reflexions. The intensities of the observed reflexions are punched on cards.
- LPST (Song Loong, 1967). Program to calculate structure factors and their standard deviation from intensities. The sorting of the structure factors necessary for making Fourier and Patterson maps is also done by this program. Calculated structure factors are written on disc.
- FDP (Song Loong, 1967). A program for computing Fourier, difference Fourier and Patterson sections.
- MFLS A local version of the ORFLS program (Busing, Martin, and Levy, 1962). This program is used in the least-squares refinements of positional and thermal parameters.
- ORTEP (Johnson, 1956). Program for preparing (stereoscopic) drawings of crystal structures. The program can also be used to calculate bond angles and distances.

2.8 Literature

- BARKER, T.V. (1911). *Min. Magazine* **16**, 212.
- BRYDEN, J.H. (1957). *Acta Cryst.* **10**, 714.
- BUSING, W.R., MARTIN, K.O., and LEVY, H.A. (1962). U.S. Atomic Energy Commission Publication, ORNL-TM-305.
- CRUICKSHANK, D.W.J. (1961). *Acta Cryst.* **14**, 1896.
- FEIL, D. and SONG LOONG, W. (1968) *Acta Cryst.* B**24**, 1334.
- HARKEMA, S., BATS, J.W., WEYENBERG, A.M. and FEIL, D. (1971). *Acta Cryst.* to be published.
- HARKEMA, S. (1968). Progress Report, Chem. Phys. Lab., Twente University of Technology, pag. J1.
- JOHNSON, C.K. (1965). U.S. Atomic Energy Commission Publication, ORNL-3794.
- LONSDALE, K. (1940). *Proc. Roy. Soc.* A**177**, 272.
- SELMAN, W.F. and HARKEMA, S. (1971). Progress Report, Chem. Phys. Lab., Twente University of Technology.
- SONG LOONG, W. (1967). Thesis, Twente University of Technology.
- STEWART, R.F., DAVIDSON, E.R., and SIMPSON, W.T. (1965). *J.Chem. Phys.* **42**, 3175.
- STOUT, G.H. and JENSEN, L.H. (1968). X-ray Structure Determination, *McMillan*, London.
- WOOLFSON, M.M. (1961), Direct Methods in Crystallography, *Clarendon*, Oxford, chapter 3.
- WORSHAM, J.E., LEVY, H.A., and PETERSON, S.W. (1957). *Acta Cryst.* **10**, 319.
- ZACHARIASEN, W.H. (1952). *Acta Cryst.* **5**, 68.

CHAPTER III

COMPARISON OF X-RAY AND NEUTRON STRUCTURE
DETERMINATION OF URONIUM NITRATE

3.1. The neutron determination

After the work described in the preceding chapter was completed a paper (Worsham and Busing, 1969) giving the structure determination of uronium nitrate by means of neutron diffraction was announced*. In this chapter a comparison of the two structure determinations by different methods will be made**

X-ray and neutron diffraction, although they are very similar to each other, have a different basis. In X-ray diffraction electromagnetic radiation is scattered by the electrons. Therefore X-ray diffraction gives information on electron density. Thermal neutrons ($\lambda \sim 1 \text{ \AA}$) however, are scattered by the nuclei of the atoms (interaction by nuclear forces). Exceptions are magnetic materials. In this case there may be an appreciable interaction between electrons and neutrons. Generally speaking neutron diffraction produces results as to positions and thermal parameters of the atomic nuclei.

The scattering power of atoms (atomic form factor) for X-rays decreases rapidly with increasing $\sin\theta/\lambda$. The scattering power is, at small values of $\sin\theta/\lambda$, roughly proportional to the number of electrons in the atom. For this reason parameters of light atoms in structures containing heavy atoms can not be determined with high accuracy by means of X-ray diffraction. The scattering powers of atoms of neighbouring elements in the periodic system are very similar. In contrast to this the scattering power of atoms for neutrons is constant for all values of $\sin\theta/\lambda$, owing to the fact that the dimension of the atomic nucleus is small compared with the wavelength normally used in neutron diffraction experiments.

The behaviour of the scattering power as a function of the constitution

* We thank Dr. Worsham and Dr. Busing for sending a preprint of their paper and the ready access they gave to their data.

** We also learned that a second X-ray diffraction experiment on uronium nitrate has been carried out (White and Mason, 1968). The results of this work are very similar to the results given in chapter II.

of the nucleus is rather erratic. Elements which are neighbours in the periodic system (or even different isotopes of the same atom) can have very different scattering power. There is no systematic trend of the scattering power with increasing atomic number.

Some advantages of neutron over X-ray diffraction, which are connected with these properties are:

- (1) Parameters of heavy and light atoms (especially hydrogen) can be determined with almost the same accuracy.
- (2) Generally more reflexions can be determined with neutrons, due to the scattering power for neutrons, which is a constant for all values of $\sin\theta/\lambda$.
- (3) Atoms with nearly the same number of electrons can sometimes be distinguished easily (for instance transition metal ions).

The greatest disadvantage of neutron diffraction is the fact that the intense neutron beam required can only be provided by a high flux nuclear reactor.

The neutron diffraction experiments on uronium nitrate were carried out by Worsham and Busing (1969) on the Oak Ridge automatic neutron diffractometer. Reflexions were measured at room temperature (22°C). The intensities were corrected for absorption ($\mu r \sim .5$). The number of reflexions measured was 1774, of which 1311 were classified as observed. The final R-factor after refinement of positional and thermal parameters in anisotropic form was 5.5%. This figure was obtained by refinement of observed reflexions only. To minimize extinction effects the 35 strongest reflexions were omitted from the last cycles of refinement. The least squares refinement was carried out so as to minimise $\sum w |F_o^2 - F_c^2|^2$, in which w is a weighting function and F_o and F_c are observed and calculated structure factors.

3.2 Reasons for differences between X-ray and neutron parameters.

When positional and thermal parameters obtained by X-ray and neutron diffraction are compared, systematic differences are frequently found. (Coppens and Vos, 1971; Coppens, Sabine, Delaplane and Ibers, 1969).

Hamilton (1969) has given a review on the significance of the differences found. According to his results some of the differences in parameters are significant. The differences are related to failures of the scattering model normally used in X-ray diffraction (spherical atoms in their ground state). The main points in which the 'classical' X-ray scattering model may be in error have been summarized by Coppens (1969). The changes in the electron density of free atoms which occur upon chemical bonding may be described by the following mechanisms, some of which are related to each other.

(1) *The formation of an overlap density.*

When atoms form a molecule electrons are normally transferred into the regions between the two atoms. This can be shown by the simplest molecular orbital treatment of the smallest molecule: the hydrogen molecule ion. (Eyring, Walter and Kimball, 1944; chapter 11). The same trend may be found in accurate calculations on more complex molecules. (Ransil and Sinai, 1967). This increase in density is due to the overlap of wavefunctions. Therefore it is called overlap density. Owing to its diffuse character the scattering of overlap densities becomes negligibly small beyond $\sin\theta/\lambda = .5$. (section 5.4, figures 5.3 and 5.4).

(2) *The formation of prepared valence states.*

Quantumchemical calculation of the M.O.-L.C.A.O.type can be made easier by taking as a basis set the so called hybridised atomic wave functions instead of the 'normal' s and p orbitals (Eyring, Walter and Kimball, 1944, chapter 12). The hybrids on an atom may contain one or two electrons. In the latter case the orbital does not participate in the bonding and the electrons of the orbital are called lone pair electrons. The necessary hybridisation is obtained by promotion of a 2s electron to a 2p atomic orbital.

(3) *Charge migration (ionicity)*

Due to the formation of a molecule migration of charge from one atom to others (or from one orbital to another) may take place. The resulting net charges on the atoms may be several electronic charges (ionic compounds) or fractions of the electronic charge (covalent compounds).

(4) *Orbital contraction or expansion.*

The scattering model for X-ray is based on atomic wave functions calculated for isolated atoms in their ground state. Model calculations (Hehre, Stewart and Pople, 1969) show that better results in calculations on molecular systems can be obtained by allowing a contraction or expansion of the atomic orbitals used.

The four mechanisms described have as a consequence that parameters obtained by X-ray diffraction may be in error. The effect of the redistribution of valence electrons can be compensated by an 'adjustment' of position as well as thermal parameters. The greater part of the effect one wishes to determine is 'refined' away in the course of normal X-ray diffraction calculations. A clear illustration of this effect is given by Coppens, Sabine, Delaplane and Ibers (1969) in their work on oxalic acid dihydrate. Two Fourier synthesis maps, showing the difference between the observed and calculated electron density, are given. One map, made after completion of the normal X-ray refinement, hardly contains any significant information on bonding electron density. The other map, giving the difference in electron density between the observed structure and a model based on the neutron positional and thermal parameters, clearly shows signi-

ficant effects attributable to a redistribution of valence electron density. It is evident that there is a strong correlation between the effects one wishes to determine (the redistribution of valence electrons) and thermal and positional parameters of the atoms as determined by X-ray diffraction.

Therefore a determination of electron redistribution from X-ray data can be made only when sufficient data have been collected in that part of reciprocal space where the influence of valence electron scattering is small: i.e. at high values of $\sin\theta/\lambda$. Another way is of course the determination of parameters by means of a method which is not influenced by the redistribution of valence electrons, for instance neutron diffraction.

The effects of the different mechanisms described above on thermal and positional parameters will be considered separately.

The presence of the *overlap density* will move the centroid of the charge cloud (the position determined by X-ray diffraction) towards the midpoint of the bond. In a model calculation for the hydrogen molecule Stewart, Davidson and Simpson (1965) found that the position of the atom determined by X-ray diffraction, compared with the position of the atomic nucleus, may be shifted towards the bonding region by an amount of $.1\text{\AA}$. The shifts expected for heavy atoms are smaller due to the presence of the core electrons, which are unaffected by chemical bonding.

Lone pair electrons give rise to a migration of the centroid of the charge cloud in the direction of the lone pair orbital. In an order of magnitude calculation Coppens and Coulson (1967) give a computation of the maximum shift expected for the X-ray parameter of a terminal oxygen atom in a nitro group. They find that the expected shift due to the lone pair electrons is $.04\text{\AA}$ in a direction away from the bonding region. The shift due to the overlap density of σ and π electrons is calculated as $.02\text{\AA}$ in a direction opposite to the shift caused by the lone pair electrons. The net shift is $.02\text{\AA}$ away from the bonding region. The shifts found in a combined X-ray and neutron diffraction experiment will be smaller than the value of $.02\text{\AA}$ owing to the fact that the position determined by X-ray diffraction is a weighted mean of the electron density distribution. The weighting function depends on the ratio of the scattering powers due to valence and core electrons. This ratio in turn is a function of $\sin\theta/\lambda$. The shifts actually found, summarized by Coppens et al (1969), are of the order of $.005\text{\AA}$ in the directions predicted by Coppens and Coulson (1967).

As the effect of overlap density is to remove electron density from the centre of the atom, one can expect that temperature factors determined by X-ray analysis are greater than the corresponding ones resulting from neutron diffraction.

The errors in X-ray parameters introduced by *Ionicity* and *Orbital Contraction* will mainly affect thermal parameters. The effect of orbital contraction is demonstrated by Stewart, Davidson and Simpson (1965). They found that, when one tries to describe the electron density in the hydrogen molecule as a

sum of spherical densities, the best fit is obtained when one uses a spherical density which is contracted compared with the electron density in the hydrogen atom.

Summarizing experimental and theoretical evidence on errors introduced by the use of spherical scattering factors of the atoms in the ground state in X-ray crystallographic structure determinations, the following conclusion can be drawn. As far as *position parameters* of heavy atoms are concerned no gross errors are expected, due to the fact that the scattering of the valence electrons is small compared with the total scattering of the atom. For second row atoms the errors expected are also small. This is caused by the fact that the possible shifts due to the overlap densities in the different bonds to one atom or due to overlap densities and the lone pair electrons cancel each other to a great extent. The shifts of the hydrogen atoms are expected to be in the direction of the midpoint of the bond due to the fact that the shift caused by the bonding electrons cannot be compensated by lone pair electrons.

Due to the deformation of the electron density upon the formation of a molecule *temperature factors* determined by X-ray diffraction are significantly greater than the ones determined by neutron diffraction (Hamilton, 1969). The overall difference is of the order of magnitude of 10 - 20% at room temperature. In certain directions, however, the differences may be greater (Coppens et al. 1969). The directions of the maximum deviation are closely related to the directions in which large deviations from spherical symmetry are expected.

It should be pointed out that all conclusions in this field have been drawn mainly on qualitative arguments. A model calculation on a compound, of which the electronic structure is known with great accuracy, can be very helpful in understanding how different X-ray parameters are affected by electron redistribution due to chemical bonding. Such a calculation can also give information on the question to which extent the reflexions in different parts of reciprocal space are influenced by valence electron scattering.

3.3 Comparison of results.

The crystal structure of uronium nitrate as found by X-ray diffraction (chapter II) is the same as the one determined by neutron diffraction. As far as chemical features (bond lengths and angles, the position of the acidic proton) are concerned no appreciable differences are expected. This is confirmed by table 3.3, which gives bond distances determined by X-ray and neutron diffraction.

A detailed examination of the results however shows a number of minor differences which can be explained by effects due to chemical bonding in the X-ray results. Errors of this kind have been described in the preceding section.

	x/a			y/b			z/c		
	Mo 1	Mo 2	N	Mo 1	Mo 2	N	Mo 1	Mo 2	N
C	.1981(3)	.1977(2)	.1976(1)	.4105(2)	.4105(2)	.4111(1)	.2558(4)	—	.2548(2)
N(1)	.3112	.3111	.3113	.9171	.9170	.9167	.2542	—	.2541
N(2)	.3334	.3337	.3345	.3767	.3768	.3767	.2605	—	.2612
N(3)	.1010	.1011	.1013	.2963	.2963	.2960	.2537	—	.2542
O(1)	.3521	.3523	.3525	.7723	.7723	.7727	.2493	—	.2500
O(2)	.1871	.1874	.1883	.9460	.9460	.9460	.2602	—	.2608
O(3)	.3969	.3967	.3964	.0297	.0297	.0292	.2517	—	.2513
O(4)	.1497	.1499	.1501	.5613	.5613	.5605	.2484	—	.2489
H(1)	.402(4)	.402(3)	.4077(4)	.451(4)	.452(3)	.4624(3)	.259(5)	—	.2565(6)
H(2)	.371	.368	.3668	.266	.266	.2548	.277	—	.2654
H(3)	.133	.138	.1299	.177	.177	.2766	.245	—	.2563
H(4)	-.009	-.007	-.0024	.325	.325	.3276	.243	—	.2483
H(5)	.233	.230	.2286	.648	.650	.6439	.257	—	.2515

Table 3.1

Position parameters for uronium nitrate obtained by X-ray and neutron diffraction. The values given in the different columns are: Mo 1 - X-ray parameters based on the refinement of all data, Mo 2 - X-ray parameters based on the refinement in which z/c parameters were fixed at the neutron values, N - Neutron parameters.

Position parameters determined by the two methods are given in table 3.1. Differences in these parameters (X-ray-neutron values) have been collected in table 3.2. As described in section 2.5 a rather strong correlation was found between the x and z coordinates of the atoms. This correlation can be seen in table 3.2. Differences in these two coordinates for the heavy atoms are nearly always in the same direction. The summation of $\Delta x\Delta z/(ac)$ over all heavy atoms gives a value of 281×10^{-8} , whereas the corresponding products $\Delta x\Delta y/(ab)$ and $\Delta y\Delta z/(bc)$ give a value of -34×10^{-8} and -63×10^{-8} respectively.

	$\Delta x/a$		$\Delta y/b$		$\Delta z/c$	
	Mo 1	Mo 2	Mo 1	Mo 2	Mo 1	Mo 2
C	5(3)	1(3)	-6(3)	-6(2)	10(4)	—
N(1)	- 1	- 2	4	3	1	—
N(2)	-11	- 8	0	1	- 7	—
N(3)	- 3	- 2	3	3	- 5	—
O(1)	- 4	- 2	- 4	- 4	- 7	—
O(2)	-12	- 9	0	0	- 6	—
O(3)	5	3	5	5	4	—
O(4)	- 4	- 2	8	8	- 5	—
H(1)	-60(40)	-60(40)	- 90(40)	-100(40)	20(50)	—
H(2)	40	10	110	110	120	—
H(3)	30	80	0	0	- 110	—
H(4)	-70	-50	- 30	- 30	- 50	—
H(5)	40	10	40	60	50	—

Table 3.2.

Differences in positional parameters (X-ray values-neutron values) multiplied by 10^4 . The meaning of the different columns is as in table 3.1.

To eliminate this correlation problem a refinement was made in which the z/c parameters of all atoms were fixed at the neutron values, which are more accurate. Parameters resulting from this refinement are also given in tables 3.1 and 3.2. The resulting R-factors ($R=6.2\%$, $R_w=4.2\%$) are nearly as good as the factors found after refinement of all parameters ($R = 6.1\%$; $R_w = 4.1\%$).

As seen from table 3.2 the resulting x/a parameters are in better agreement with neutron parameters than the corresponding values after refinement of all parameters. (The sum of the squares of the differences decreased from 357×10^{-8} to 171×10^{-8}). Differences found for the heavy atoms are displayed in figure 3.1. Although the magnitude of many of the shifts found is not significant, the direction of most shifts is in a direction which can be predicted from a redistribution of valence electrons. As a result of the differences bond lengths derived by X-ray diffraction shows systematic deviations from the neutron values.

Table 3.3 (in which bond lengths are compared) gives as a trend that all bond lengths concerning an oxygen atom are longer when determined by X-ray diffraction. This deviation is due to the presence of lone pair electrons. The two C–N bonds are shorter than the corresponding neutron values due to the fact that the influence of overlap density in the C–N bond is stronger than the overlap densities in the N–H bonds. The difference in the two C–N distances which is quite appreciable in the X-ray experiment, is seen to be

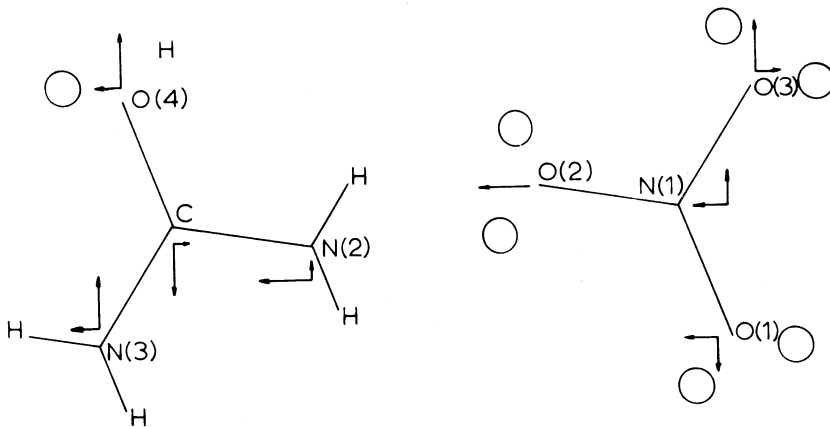

Figure 3.1

Differences between X-ray and neutron position parameters for the heavy atoms in uronium nitrate. The regions of the lone pair electrons are also indicated in this figure.

	X	N		X	N
N(1)-O(1)	1.256(4)	1.250(1)	N(2)-H(1)	.90(5)	1.005(3)
N(1)-O(2)	1.233	1.227	N(2)-H(2)	.96	1.013
N(1)-O(3)	1.242	1.236	N(3)-H(3)	1.03	1.014
C -N(2)	1.301	1.312	N(3)-H(4)	1.04	1.000
C -N(3)	1.312	1.315	O(4)-H(5)	1.04	1.006
C -O(4)	1.311	1.298			

Table 3.3

Bond lengths in Å as determined by X-ray and neutron diffraction. Columns marked X: X-ray results; N: Neutron results.

very small from the (more accurate) neutron results. It is interesting to note that White and Mason (1968) found the same inequivalence in C–N bond lengths by means of X-ray diffraction. The conclusions on differences in bond lengths, when comparing X-ray and neutron diffraction results, are fully supported by their work.

Contrary to what is generally found, not all bond lengths involving hydrogen determined by X-ray diffraction are shorter than the corresponding neutron values. Part of this may be due to correlation effects between parameters of heavy atoms and hydrogen atoms. This is supported by the fact that when a refinement is made on position and thermal parameters of the hydrogen atoms (the parameters of the heavy atoms being fixed at the neutron values) all bonds to hydrogen atoms except one are shorter than the corresponding neutron values.

Considering *thermal parameters*, which are given in table 3.4, it is found that for the heavy atoms the X-ray values are nearly always greater than the neutron values. The differences in thermal parameters, which may be quite appreciable, are collected in table 3.5, which gives the differences in U_{ii} parameters. These parameters are related to the mean square displacements along the reciprocal axes. The mean difference between X-ray and neutron values is of the order of magnitude of two standard deviations. Differences of this magnitude are commonly found when comparing X-ray and neutron values for thermal parameters. The fact that differences in specific directions

	U ₁₁		U ₂₂		U ₃₃		U ₁₂		U ₁₃		U ₂₃	
	X	N	X	N	X	N	X	N	X	N	X	N
C	346(16)	291(6)	206(14)	181(4)	371(21)	409(6)	- 3(13)	13(3)	208(16)	227(5)	24(13)	18(4)
N(1)	385(14)	313(3)	226(12)	174(4)	521(21)	468(4)	26(12)	3(3)	294(15)	262(2)	8(12)	8(3)
N(2)	388(15)	363(3)	273(15)	238(4)	654(22)	597(6)	- 9(13)	13(3)	370(16)	344(5)	5(14)	0(3)
N(3)	391(15)	366(3)	223(13)	211(4)	662(21)	629(6)	- 28(12)	-10(3)	349(16)	338(5)	10(14)	36(3)
O(1)	580(14)	501(6)	157(10)	164(6)	938(20)	857(12)	37(10)	23(7)	541(15)	502(10)	11(12)	18(5)
O(2)	488(14)	488(6)	305(13)	259(6)	1019(24)	1077(16)	15(11)	- 7(7)	578(16)	574(10)	3(13)	- 10(8)
O(3)	475(13)	404(6)	205(10)	211(4)	761(19)	714(10)	- 46(10)	- 13(3)	442(14)	401(7)	6(11)	5(5)
O(4)	447(13)	398(6)	182(10)	181(4)	723(18)	670(10)	42(9)	29(3)	385(13)	391(7)	20(11)	23(5)

Table 3.4.

Vibration parameters (multiplied by 10^4) determined by X-ray and neutron diffraction. The temperature factor expression used is given in table 2.2.

	ΔU_{11}	ΔU_{22}	ΔU_{33}
C	54(15)	27(12)	-38(21)
N(1)	72	52	53
N(2)	23	35	57
N(3)	24	12	33
O(1)	79	- 7	81
O(2)	0	46	-56
O(3)	71	- 6	47
O(4)	49	1	53

Table 3.5

Differences in the U_{ii} thermal parameters (multiplied by 10^4). The number given is the X-ray value minus the neutron value.

may be influenced by bonding effects can be demonstrated by considering the thermal parameters for the oxygen atoms in the xy plane. It is found that the maximum differences are found in the directions which are related to the positions of the lone pair electrons. For instance the lone pair electrons of O(2) are contained in two regions on opposite sides of the x -axis. The electron density in these regions has been compensated by an increase in the U_{22} X-ray thermal parameters.

To get an impression what errors are compensated in the course of X-ray refinement, a difference Fourier synthesis map was calculated using structure factors based on X-ray experiments and positional and thermal parameters derived from neutron diffraction. The R-factor in this case ($R = 5.7\%$) is greater than found after 'conventional' X-ray refinement ($R = 4.1\%$). The difference Fourier synthesis is shown in figure 3.2 together with the final X-ray difference map. As can be seen from the map the biggest differences in the map are in the regions in which the electron density is strongly affected by chemical bonding. In the uronium ion for instance a positive electron density is found in all the bonds. Furthermore an excess electron density is found near O(4)

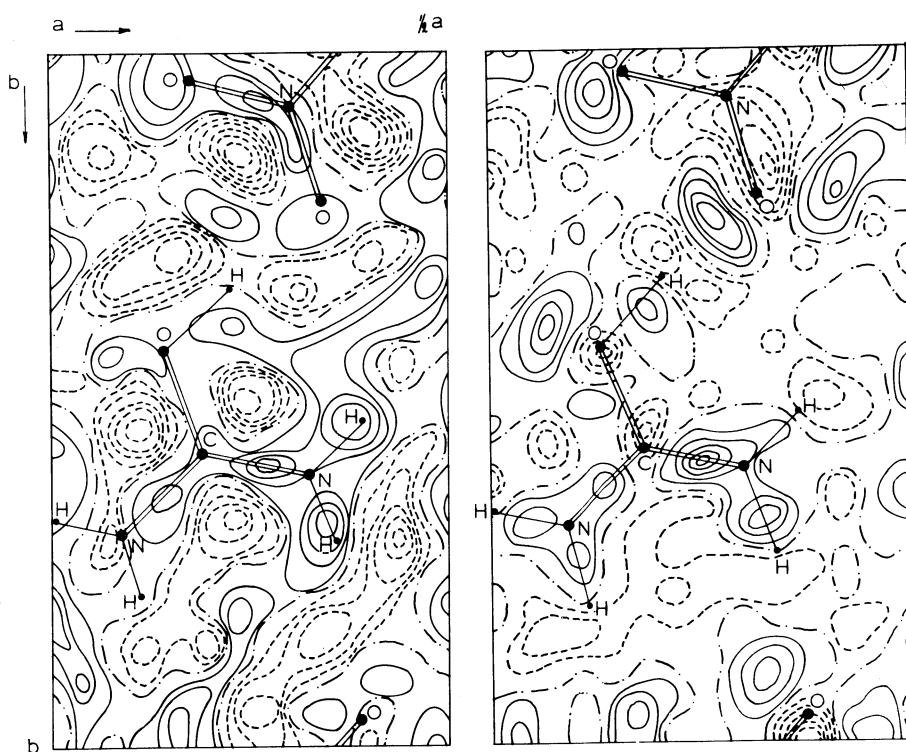

Figure 3.2

Difference Fourier synthesis maps ($z/c = .25$)
 left: Final X-ray map. Interval between two contour lines $.02 e \text{ \AA}^{-3}$.
 right: Combined X-ray and neutron map. Interval: $.05 e \text{ \AA}^{-3}$.

in the region in which the lone pair electrons are expected. The most important feature in the neighbourhood of the nitrate ion is the presence of electron density due to the lone pair electrons of the oxygen atoms. Many of these features have disappeared in the final X-ray difference map, the one based on 'accommodated' parameters.

Reviewing this chapter it can be concluded that most of the differences between X-ray and neutron parameters found in uronium nitrate are due to failures in the scattering model commonly used in X-ray diffraction.

3.4 Literature

- COPPENS, P. (1969). *Acta Cryst.* **A25**, 180.
COPPENS, P. and COULSON, C.A. (1967). *Acta Cryst.* **23**, 718.
COPPENS, P., SABINE, T.M., DELAPLANE, R.G. and IBERS, J.A. (1969). *Acta Cryst.* **B25**, 2451.
COPPENS, P. and VOS, A. (1971). *Acta Cryst.* **B27**, 146.
EYRING, H., WALTER, J. and KIMBALL, G.E. (1944). *Quantum Chemistry*, Wiley, New York.
HAMILTON, W.C. (1969). *Acta Cryst.* **A25**, 194.
HEHRE, W.G., STEWART, R.F., POPLÉ, J.A. (1969). *J. Chem. Phys.* **51**, 2657.
RANSIL, B.J. and SINAI, J.J. (1967). *J. Chem. Phys.* **46**, 4050.
STEWART, R.F., DAVIDSON, E.R. and SIMPSON, W.T. (1965). *J. Chem. Phys.* **42**, 3175.
WHITE, J.C.B. and MASON, S.A. (1968), private communication.
WORSHAM, J.E. and BUSING, W.R. (1969). *Acta Cryst.* **B25**, 572.

CHAPTER IV

SEMI-EMPERICAL QUANTUMCHEMICAL CALCULATIONS
ON URONIUM NITRATE

4.1 Introduction

This chapter describes semi-empirical calculations on the uronium nitrate molecule. These calculations were carried out by C.N.D.O./2 method. (Pople and Segal, 1966). A brief description of the method employed and the results of a number of calculations will be given.

The problem with which one is confronted in energy calculations on atomic or molecular systems is to find an (approximate) solution of the eigenvalue equation:

$$\hat{H}\psi = E\psi \quad (4.1)$$

in which \hat{H} is the Hamiltonian operator of the system under consideration and ψ is the molecular wave function which depends on the coordinates of all electrons and nuclei. Within the Born-Oppenheimer approximation the Hamiltonian (in atomic units) for the electrons is given by:

$$\hat{H} = \sum_{\alpha} \hat{H}_{N}(\alpha) + \sum_{\alpha, \beta} \frac{1}{r_{\alpha\beta}} \quad \beta < \alpha \quad (4.2)$$

The summations extend over all electrons. The $1/r_{\alpha\beta}$ term of equation (4.2) represents the electronic repulsion. The Hamilton operator for electron α in the field of all nuclei is given by:

$$\hat{H}_{N}(\alpha) = -\frac{1}{2}\nabla_{\alpha}^2 - \sum_a \frac{Z_a}{r_{\alpha a}} \quad (4.3)$$

The term $-\frac{1}{2}\nabla_{\alpha}^2$ is the kinetic energy operator. The last term in (4.3) is the interaction between electron α and the nucleus a with charge Z_a . The summation a is over all nuclei. An exact solution of equation (4.1) as far as molecules are concerned has only been given for the simplest molecule: the hydrogen molecule ion. In all other cases we have to content ourselves with appro-

ximate solutions. It is possible to express any exact or approximate solution of equation (4.1) as a linear combination of so called Slater determinants. The Slater determinants are constructed from a complete set of one electron spin orbitals. State functions written in this form have the property of being anti-symmetric with respect to interchanging of electrons.

The approximation scheme commonly adopted in atomic and molecular calculations in the so-called Hartree - Fock or Self Consistent Field method. The outlines of calculations in the molecular field (closed shell) have been given by Roothaan (1951). In this method one determines the best wave function (with regard to the energy) which can be written as a single Slater determinant. In determining this wave function one makes use of the variation principle which states that any approximate solution of eq. (4.1) for the ground-state of the system has a higher energy than the exact solution. The orthonormal one electron Molecular Orbitals Φ_j which compose the Slater determinant are given as a Linear Combination of Atomic Orbitals χ_ν (L.C.A.O. - M.O. method).

$$\Phi_i = \sum_{\nu} c_{\nu i} \chi_{\nu} \quad (4.4)$$

The summation ν is over all atomic orbitals in the basis set (the set of orbitals from which the M.O. is constructed). The coefficients $c_{\nu i}$ are treated as variational parameters determined by the condition that the energy of the ground state is a minimum. This requirement leads to the so-called Roothaan equations written in matrix form:

$$\mathbf{F} \mathbf{C} = \mathbf{S} \mathbf{C} \mathbf{E} \quad (4.5)$$

In this equation \mathbf{F} and \mathbf{S} are known matrices defined below. The matrix \mathbf{C} contains the coefficients of the orbitals given in equation (4.4). The matrix \mathbf{E} is a diagonal matrix giving the energy of the M.O.'s.

The elements of the matrices \mathbf{F} and \mathbf{S} are given by the following equations:

$$F_{\mu\nu} = H_{\mu\nu} + G_{\mu\nu} \quad (4.6)$$

$$H_{\mu\nu} = \int \chi_{\mu}^*(1) \hat{H}_N(1) \chi_{\nu}(1) d\tau_1 \quad (4.7)$$

($\hat{H}_N(1)$ has been defined in (4.3))

$$G_{\mu\nu} = \sum_{\lambda, \sigma} P_{\lambda\sigma} [(\mu\nu|\lambda\sigma) - \frac{1}{2}(\mu\sigma|\nu\lambda)] \quad (4.8)$$

$$(\mu\nu|\lambda\sigma) = \int \chi_{\mu}^*(1) \chi_{\nu}(1) \frac{1}{r_{12}} \chi_{\lambda}^*(2) \chi_{\sigma}(2) d\tau_1 d\tau_2 \quad (4.9)$$

$$S_{\mu\nu} = \int \chi_{\mu}^*(1) \chi_{\nu}(1) d\tau_1 \quad (4.10)$$

$$P_{\lambda\sigma} = 2 \sum_i c_{\lambda i}^* c_{\sigma i} \quad (4.11)$$

In these equations $H_{\mu\nu}$ is the matrix element of the Hamiltonian, giving the energy of an electron in the field of all nuclei. The matrix elements $G_{\mu\nu}$ represent the electronic interactions. These matrix elements are dependent on the population matrix elements $P_{\lambda\sigma}$ and therefore on the elements of the \mathbf{C} matrix. The summation in (4.11) is over all occupied M.O.'s. (In a closed shell ground state the lowest M.O.'s are occupied by two electrons with opposite spins).

In actual calculations the following scheme is followed. Make a first guess for the \mathbf{C} matrix, compute \mathbf{F} (eq. (4.6), (4.7) and (4.8)) and then solve eq. (4.5). In this way a new \mathbf{C} matrix is obtained which can be used to construct a new \mathbf{F} matrix. This procedure is repeated a number of times until self-consistency is reached.

4.2 The C.N.D.O./2 method.

The number of molecules for which calculations following the S.C.F. method have been performed is rather limited. This limitation is due to the fact that calculations along these lines are very time-consuming. The step which takes most of the computer time is the calculation of the matrix elements of eq. (4.9) owing to their very large number and the complexity of the calculations of some elements. In a recent calculation (Clementi, Mehl and von Niesen, 1971) on one of the largest molecular systems treated in this way, the number of electronic repulsion integrals in the first S.C.F. cycle was 2.4×10^9 . The molecule consisted of 29 atoms and contained 136 electrons. The integral calculation took 48 hours on one of the most powerful computer systems available today.

In order to simplify S.C.F. calculations various approximation schemes have been developed. In these methods a number of integrals is neglected or approximated by empirical values. A review of these semi-empirical approximation schemes has been given recently by Klopman and O'Leary (1970). In our calculations the C.N.D.O./2 method as developed by Pople, Santry and Segal (1965^a, 1965^b, 1966) was used. A short description of the assumptions made in this method will be given below.

- (1) The first approximation made is the so-called Zero Differential Overlap approximation:

$$\chi_{\mu}(1)\chi_{\nu}(1) = 0 \quad \text{for} \quad \mu \neq \nu \quad (4.12)$$

By this approximation the number of integrals to be calculated is reduced drastically because all integrals in eq. (4.9) which apply to 3 or 4 different centers are neglected. The two center integrals retained in the calculations are of the type:

$$\gamma_{\mu\nu} = (\mu\mu | \nu\nu) \quad (4.13)$$

All other two center integrals are neglected. The Z.D.O. approximation may be partially justified by assuming that the basis orbitals are so-called Löwdin orbitals (Parr, 1964).

- (2) In order to retain invariancy under a rotation of axes, additional approximations have to be made to the $\gamma_{\mu\nu}$ integrals. Invariancy is obtained by requiring that the integrals $\gamma_{\mu\nu}$ depend only on the atoms to which χ_{μ} and χ_{ν} belong and not on the type of orbitals (s,p) under consideration.
- (3) Approximations similar to assumption (1) and (2) have also to be made to the $H_{\mu\nu}$ matrix elements (eq. (4.7)).

In this way the following expressions for the $F_{\mu\nu}$ elements have been obtained (Pople and Segal, 1966)

$$F_{\mu\nu} = -\frac{1}{2}(I_{\mu} + A_{\mu}) + [(P_{aa} - Z_a) - \frac{1}{2}(P_{\mu\mu} - 1)] \gamma_{aa} + \sum_{b \neq a} (P_{bb} - Z_b) \gamma_{ab} \quad (4.14)$$

$$F_{\mu\nu} = \frac{1}{2}(\beta_a + \beta_b) S_{\mu\nu} - \frac{1}{2}P_{\mu\nu} \gamma_{ab} \quad (4.15)$$

In these equations I_{μ} and A_{μ} are the ionisation potential and electron affinity of the atomic orbital μ (which belongs to atom a). The terms P_{aa} and $P_{\mu\mu}$ represent the number of electrons on atom a and in molecular orbital μ respectively. In equation 4.15 the terms β_a and β_b are empirical constants which depend on the type of atom (a,b) to which the atomic orbitals ν and μ belong. $S_{\mu\nu}$ is an element of the overlap matrix (eq. (4.10)), which is not neglected

here as might be expected from the Z.D.O. approximation. The values of $I_{\mu} + A_{\mu}$ are derived from atomic spectral data. The values used in our calculations are those given by Pople and Segal (1966). The values of the β 's are chosen in such a way that C.N.D.O. calculations give the best fit with more accurate S.C.F. calculations on small molecules. Values of the β parameters have been given by Pople and Segal (1965^b). The program used was a slightly modified version of a program written by Segal and distributed by Q.C.P.E. (1969). A number of calculations by the C.N.D.O./2 method were carried out. The results of the computations on different molecules and groups will be given in the next sections.

4.3 Calculations on the urea molecule

In order to see whether the C.N.D.O./2 method is capable of predicting geometric data, several calculations on the urea molecule have been done at different geometries. In accordance with experimental evidence (Pryor and Sanger, 1970) the urea molecule was assumed to be planar and to have reflection symmetry. Bond lengths used in the calculation were chosen as in the uronium ion to give a common basis to different calculations. (C–O: 1.307Å; C–N: 1.308Å; N–H: 1.00Å). The angles around the nitrogen atoms were kept arbitrarily at 120°. Calculations were performed for a number of different values of the angle α as defined in figure 4.1., ranging from 100° to 140° with intervals of 5°. The coordinates of the atoms needed for the C.N.D.O. program were obtained by means of a small computer program to secure the accuracy of the input data. For each of the geometries the total energy was computed as a sum of the electronic energy and the repulsion due to the charges of the different nuclei and cores. The electronic energy is calculated according to

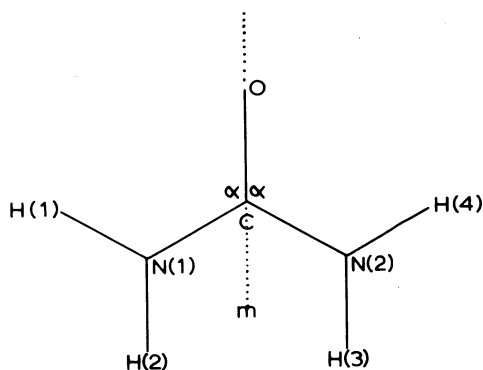

Figure 4.1
The geometry of the urea molecule

the formula:

$$E_{\text{el.}} = \frac{1}{2} \sum_{\mu, \nu} P_{\mu\nu} (H_{\mu\nu} + F_{\mu\nu}) \quad (4.16)$$

Values of the total energy computed are given in table 4.1 and figure 4.2. As seen from the figure the total energy has a minimum at about 121° . The experimental value for this angle is 121.7° (Pryor and Sanger, 1970).

α	E(a.u.)	α	E(a.u.)
100	-51.6989	125	-51.7711
105	-51.7299	130	-51.7534
110	-51.7561	135	-51.7103
115	-51.7692	140	-51.6101
120	-51.7757		

Table 4.1

Total energy of the urea molecule as function of α

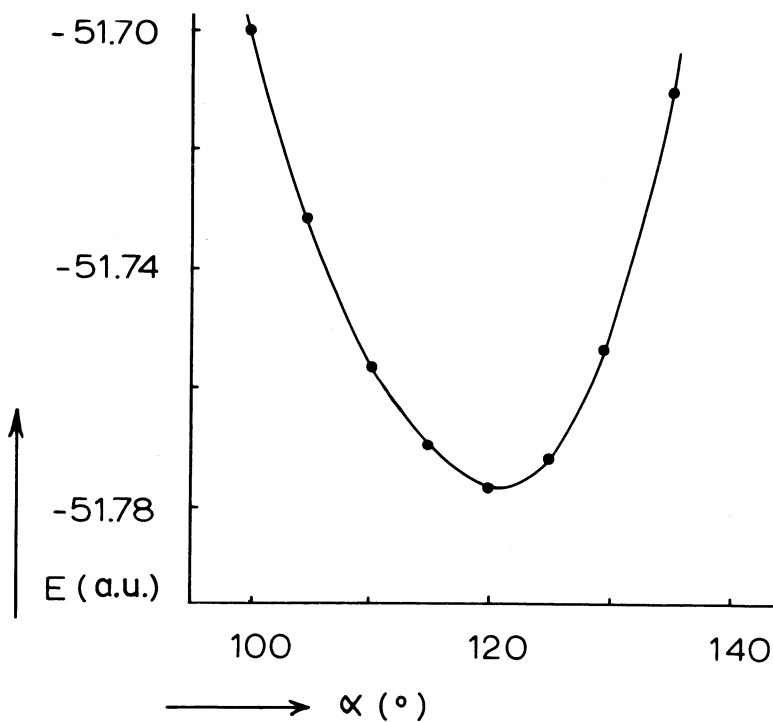

Figure 4.2

The total energy of the urea molecule as a function of α

The calculated dipole moment (including atomic dipole contributions) at the minimum energy is 5.4 D(ebye). This dipole moment should be compared with the experimental value of 4.6 D measured in dioxane at 25°C. The dipole moment of urea measured in other solvents ranges from 4.2 to 6.4 D (McClellan, 1963).

It will be assumed in this chapter that bond distances are mainly dependent on π bond orders, as is common practice in the chemistry of conjugated compounds (Häfelinger, 1970). The σ bond orders were also calculated in our computations. The results show that differences in σ bond orders are an order of magnitude smaller than differences in the corresponding π bond. This is in accordance with the π approximation theory (Parr, 1964, chapter 3) which is supposed to be valid for planar unsaturated molecules.

The π bond orders for the C–N and C–O bonds are .478 and .677 respectively. These figures show that the C–N bond has some double bond character and that the C–O bond is not a ‘pure’ double bond, indicating that a certain amount of bond delocalisation is present. In accordance with these calculations the length of the C–N bond in urea (1.352(2)Å) is less than the length of a single C–N bond (1.47(2)Å) (Häfelinger, 1970a). The length of the C–O bond (1.260(3)Å) is intermediate between the length of a single and double C–O bond (1.43(2)Å and 1.17(2)Å) (Häfelinger, 1970b).

4.4 Calculations on the uronium ion

A number of calculations were performed on the uronium ion. The total energy has been calculated as a function of the angles α and β defined in figure 4.3. Bond lengths and fixed angles were taken as in the former calculations on

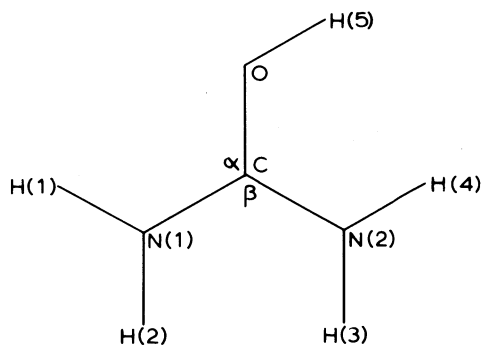

Figure 4.3

The geometry of the uronium ion

β \ α	100	110	120	130	140
100	-52.2591	-52.2850	-52.2990	-52.3010	-52.2912
110	-52.2955	-52.3177	-52.3267	-52.3221	-52.3037
120	-52.3175	-52.3346	-52.3371	-52.3240	-52.2936
130	-52.3268	-52.3371	-52.3310	-52.3059	-52.2535
140	-52.3295	-52.3278	-52.3095	-52.2625	-52.1546

Table 4.2

Total energy (a.u.) for the uronium ion at different values of α and β

β \ α	110	113.3	116.6	120
120	-52.3346	-52.3372	-52.3380	-52.3371
123.3	-52.3396	-52.3413	-52.3412	-52.3393
126.6	-52.3384	-52.3392	-52.3383	-52.3354
130	-52.3371	-52.3370	-52.3350	-52.3310

Table 4.3

Total energy (a.u.) for the uronium ion at different values of α and β

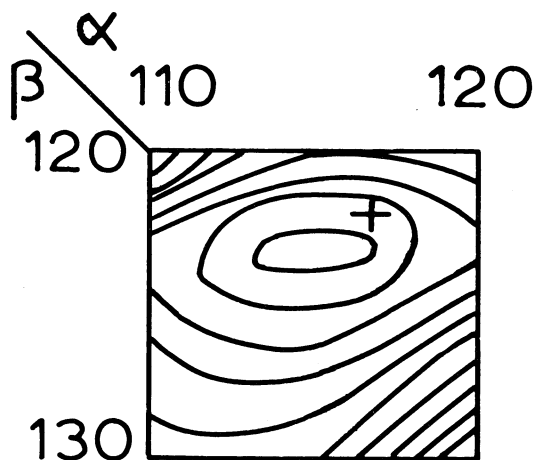

Figure 4.4

Contour diagram giving the total energy for the uronium ion as a function of α and β . The energy difference between two lines is .001 a.u. The experimental value of α and β are denoted by a^+

the urea molecule. Values of the total energy computed are given in tables 4.2 and 4.3 and in figure 4.4. From figure 4.4 it becomes evident that the calculated energy minimum is not far from the experimental one. Here, as in the case of the urea molecule, the C.N.D.O./2 method predicts bond angles which are in fair agreement with experimental ones.

The π bond orders for the C–N and C–O bonds in uronium nitrate are .595 and .443 respectively. Comparison of these values with those found in the urea molecule shows that a lengthening of the C–O and a shortening of the C–N bond is to be expected when urea is protonated. These facts are in accordance with experimental evidence as described in chapter II.

4.5 Nitrate ion

For comparison with subsequent computations the electronic structure of the nitrate ion was calculated by means of the C.N.D.O./2 method. The geometry used in the calculations was a planar ion with bond angles of 120° and N–O bond lengths of 1.238Å (mean of the experimental values found in uronium nitrate). The numbers of interest are: number of valence electrons on the N and O atoms 4.39 and 6.54 respectively; π bond order for the N–O bond: .572.

4.6 Influence of hydrogen bonding on bond lengths

A number of cases has been reported in which was stated that intramolecular bonding may be influenced by intermolecular hydrogen bonds. In a recent example (Craven, Cusatis, Gartland and Vizzini, 1969) it was found that a C=O bond is lengthened when the oxygen atom is the acceptor of a strong hydrogen bond. The increase in C=O bond length is accompanied by a shortening of the other bonds involving the carbon atom. Another example of these interactions via hydrogen bonds may be found in the structures of monomeric and dimeric carboxylic acids (Derissen, 1971). These effects are very similar to those found in donor–acceptor complexes which have been reviewed by Bent (1968). In uronium nitrate a significant difference is found in the bond length of the nitrate ion. Deformations of this kind have also been found in N–methyluronium nitrate (Selman and Harkema, 1971) and thiuronium–nitrate (Feil and Song Loong, 1968). In these compounds there is a correlation between the length of an N–O bond and the number and strength of hydrogen bonds to the oxygen atom under consideration. The shortest N–O distances are found for those oxygen atoms which are not or weakly hydrogen bonded. The longer distances occur when the oxygen atom is the acceptor of a short (strong) O–H . . . O hydrogen bond (table 4.5).

In order to see whether differences of this kind may be predicted by quantumchemical calculations we performed C.N.D.O./2 calculations on the geometries defined in figure 4.5. Intramolecular distances and angles were taken as in the former calculations. The lengths of the hydrogen bonds were assumed to be: O—H . . . O: 2.60Å; N—H . . . O: 2.96Å.

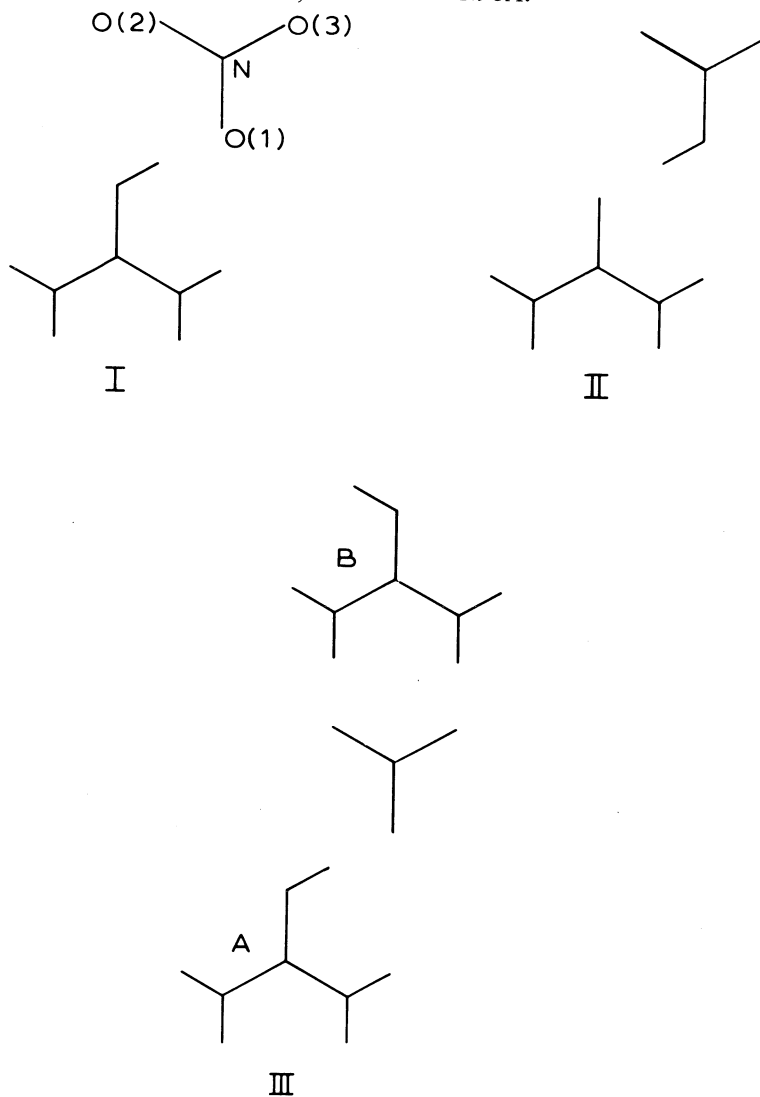

III

Figure 4.5

Arrangements of uronium and nitrate ions which have been treated by the C.N.D.O./2 method. The numbering of the atoms in uronium ion A and B is given in figure 4.3.

	a	b	c	d	e	f
C-N (1)	.478	.597	.565	.501	.572	.600
C-N (2)	.478	.593	.577	.498	.582	.598
C-O	.687	.443	.499	.647	.487	.436
N-O (1)	.572		.498	.367	.526	
N-O (2)	.572		.599	.659	.588	
N-O (3)	.572		.615	.652	.602	

Table 4.4

π bond orders for different arrangements of uronium and nitrate ions.

- a. urea molecule
 b. uronium ion
 c. uronium + nitrate ion (fig. 4.5 I)
 d. urea + nitric acid molecule (fig. 4.5 II)
 e. uronium ion (fig. 4.5 IIIA)
 f. uronium ion (fig. 4.5 IIIB)

The most important values of the π bond orders have been collected in table 4.4. From this table it is clear that calculations on bond orders indicate that bond lengths are influenced by hydrogen bonding.

Considering first the *nitrate ion*, it is seen (table 4.4 column c) that when O(1) accepts a strong hydrogen bond the result will be a decrease in N-O (1) bond order and an increase in the bond orders involving the other two oxygen atoms. When the atoms O(2) and O(3) are also (more weakly) hydrogen bonded the differences in bond orders become smaller (table 4.4, columns e + f). If on the other hand a calculation is made for the nitric acid molecule (which may be considered to be a very strong hydrogen bonded nitrate ion) differences in bond orders are considerable, resulting in a large difference in N-O bonds. Bond lengths in nitrate ions in which one oxygen atom is more strongly hydrogen bonded than others are thus expected to be intermediate between the values for the nitric acid molecule and the unperturbed nitrate ion.

a	N-O (1)	1.256 (4)	O-H . . O	2.59
	N-O (2)	1.242 (4)	N-H . . O	2.91
			N-H . . O	2.92
	N-O (3)	1.233 (4)	N-H . . O	2.95
			N-H . . O	2.98
b	N-O (1)	1.259 (4)	O-H . . O	2.57
	N-O (2)	1.246 (4)	N-H . . O	2.90
			N-H . . O	2.92
	N-O (3)	1.219 (4)	N-H . . O	2.95
c	N-O (1)	1.239 (4)	N-H . . O	2.94
			N-H . . O	2.97
	N-O (2)	1.233 (4)	N-H . . O	2.88
			N-H . . O	3.16
	N-O (3)	1.217 (4)	N-H . . O	3.16

Table 4.5

Comparison of different N-O bond lengths (Å) in uronium-, N-methyluronium-, and thiuronium nitrate. The columns of the table give bond length, type of hydrogen bond to oxygen atom of nitrate ion, length of the hydrogen bond.

- uronium nitrate (chapter II)
- N-methyluronium nitrate (Selman and Harkema, 1971)
- thiuronium nitrate (Feil and Song Loong, 1968)

Values for N-O lengths in three structures in which differently bonded nitrate ions occur are given in table 4.5. In this table bond lengths are given in decreasing order for the different molecules. The nature and number of hydrogen bonds to the oxygen atoms of the nitrate ions are also given in the table. Inspection of the table reveals that the longest N-O distances are to the oxygen atom which accepts the rather strong O-H O bond or to the atom which accepts the strongest N-H O bonds (thiuronium nitrate). The shortest N-O distances are always to the oxygen atoms which are the acceptors of the weakest N-H O bonds. Thus the expectations based on the calculations of table 4.4 are in accordance with the experimental facts (table 4.5).

Considering now bond lengths in the *uronium ion* (urea molecule) it is seen from table 4.4 that for this ion relations similar to the ones in the nitrate ion are to be expected. When the urea molecule is protonated or strongly

compound	Ref	C-N	C-O	type	length
urea	a	1.352 (2)	1.260 (2)	N-H . . . O	2.99
					2.99
					3.03
					3.03
urea-oxalic acid	b	1.320 (5)	1.260 (3)	O-H . . . O	2.47
uronium phosphate	c	1.331	1.284	O . . H . . O	2.42
N-methyluronium nitr.	d	1.308 (5)	1.301 (4)	---	---
uronium nitrate	e	1.307 (3)	1.311 (4)	---	---

Table 4.6

C-N and C-O bond length in urea compounds. The types and lengths of the hydrogen bonds to the oxygen atom are also given.

- a. Pryor and Sanger (1970)
- b. Harkema, Bats, Weijnenberg and Feil (1971)
- c. Konstanssek and Busing (1970)
- d. Selman and Harkema (1971)
- e. chapter II.

hydrogen bonded (at the oxygen atom) the C-O bond should become longer and the C-N bond somewhat shorter depending on the strength of the hydrogen bond. Bond lengths for different urea compounds have been collected in table 4.6. The compounds have been arranged in order of increasing hydrogen bond strength. In urea the oxygen atom is the acceptor of weak N-H O bonds. In urea-oxalic acid the bond concerned is a much stronger O-H O bond. In uronium phosphate a very short O H O bond is found in which the proton is shared between the two oxygen atoms. Two examples of the uronium ion are also given. From the table it can be verified that (with one exception) the C-O bond becomes longer and the C-N bond shorter, when the strength of the hydrogen bonds is increased. (When comparing values in table 4.5 it should be noted that the distances in the urea molecule are corrected for thermal motion, the others are not).

Summarizing the results of this chapter it can be stated that the C.N.D.O./2 method is capable of predicting the geometries of urea and the uronium ion. The influence of hydrogen bonds to the nitrate ion and the urea molecule can explain experimental differences in bond lengths.

4.7 Literature

- BENT, H.A. (1968). *Chem. Rev.* **68**, 587.
- CLEMENTI, E., MEHL, J. and von NIESSEN, W. (1971). *J. Chem. Phys.* **54**, 508
- CRAVEN, B.M., CUSATIS, C., CARTLAND, G.L. and VIZZINI, E.A. (1969). *Acta Cryst.* **A25**, S138.
- DERISSEN, J.L. (1971). *J. Mol. Struct.* **7**, 67.
- FEIL, D. and SONG LOONG, W. (1968) *Acta Cryst.* **B24**, 1334.
- HAEFELINGER, G. (1970^a). *Ber.* **103**, 2902.
- HAEFELINGER, G. (1970^b). *Ber.* **103**, 2922.
- HARKEMA, S., BATS, J.W., WEIJENBERG, A.M., and FEIL, D. (1971). *Acta Cryst.* to be published.
- KLOPMAN, G. and O'LEARY, B. (1970) *Topics in Current Chemistry* **15**, 447.
- KONSTANSEK, E.C., and BUSING, W.R. (1971). Private Communication.
- McCLELLAN, A.C. (1963). *Tables of Experimental Dipole Moments*, Freeman, San Francisco.
- PARR, R.G. (1964). *Quantum Theory of Molecular Electronics Structure*, Benjamin, New York.
- POPLE, J.A., SANTRY, D.P. and SEGAL, G.A. (1965^a). *J. Chem. Phys.* **43**, S129.
- POPLE, J.A. and SEGAL, G.A. (1965^b). *J. Chem. Phys.* **43**, S136.
- POPLE, J.A. and SEGAL, G.A. (1966). *J. Chem. Phys.* **44**, 3289.
- PRYOR, A.W. and SANGER, P.L. (1970) *Acta Cryst.* **A26**, 543.
- Q.C.P.E. (1969). *Quantum Chemistry Program Exchange*, Bloomington, program no.91.
- ROOTHAAN, C.C.J. (1951). *Rev. Mod. Phys.* **23**, 161.
- SELMAN, W.F. and HARKEMA, S. (1971) Progress Report, *Chem. Phys. Lab.*, Twente University of Technology.

CHAPTER V

CALCULATIONS WITH DIFFERENT
FORM FACTOR MODELS

5.1 Introduction

In the preceding chapters it has been shown that comparison of X-ray and neutron diffraction results can give information on the redistribution of charge which occurs when atoms combine to form a molecule. Furthermore it has been shown that quantumchemical methods exist which can predict a number of geometrical properties of urealike molecules. The quantummechanical methods also provide a means by which charge distributions may be estimated. The purpose of this chapter is to investigate what information on electron density is obtainable from diffraction experiments.

The coherent scattering power f of a system of N -electrons described by the state function ψ is:

$$f(\mathbf{s}) = \int \psi^* \sum_{i=1}^N \exp(i\mathbf{s}\cdot\mathbf{r}_i) \psi \, d\mathbf{r}_1 \dots d\mathbf{r}_N \quad (5.1)$$

In this formula \mathbf{s} is the scattering vector (James, 1965, chapter 3). In the case that the wave function is composed of a single Slater determinant constructed from orthogonal Molecular Orbitals ϕ_i , formula 5.1 may be written as-

$$f(\mathbf{s}) = \sum_{i=1}^N \int \phi_i^* \exp(i\mathbf{s}\cdot\mathbf{r}) \phi_i \, d\mathbf{r} \quad (5.2)$$

In the M.O.-L.C.A.O. approximation (chapter 4) this equation can be reduced to a sum of terms involving atomic orbitals:

$$f(\mathbf{s}) = \sum_{i=1}^{\text{occ}} \sum_{\mu, \nu} c_{\mu i} c_{\nu i} f_{\mu\nu}(\mathbf{s}) = \sum_{\mu, \nu} P_{\mu\nu} f_{\mu\nu}(\mathbf{s}) \quad (5.3)$$

$$f_{\mu\nu}(\mathbf{s}) = \int \chi_{\mu}^* \exp(i\mathbf{s}\cdot\mathbf{r}) \chi_{\nu} \, d\tau \quad (5.4)$$

In eq. 5.3 and 5.4 the summations μ and ν extend over all atomic orbitals used in the basis set. The summation i is over all occupied M.O.'s. The problem of calculating form factors for molecular systems is thus reduced to the

calculation of form factors $f_{\mu\nu}(s)$ involving at most two different atomic centers. The relation between quantumchemical calculations and molecular scattering is via the $P_{\mu\nu}$ coefficients. The $P_{\mu\nu}$ terms (elements of the charge-bond order matrix) are the results of quantumchemical calculations.

5.2 Basis functions

The wave functions (atomic orbitals) used as a basis in atomic and molecular orbital calculations are usually given as a product of a radial part $R(r)$ and angular part $Y_{lm}(\Theta, \phi)$ (spherical harmonics):

$$\chi(r, \Theta, \phi) = R(r) Y_{lm}(\Theta, \phi) \quad (5.5)$$

(Eyring, Walter, Kimball, 1944, chapter 9). The $R(r)$ and $Y_{lm}(\Theta, \phi)$ are normalized functions. In describing the radial part of the wave functions two types of functions are commonly employed: Slater and Gauss functions.

Slater Type Orbitals with quantum number n are defined by:

$$\chi_n^S = N_n^S r^{n-1} \exp(-\zeta r) \quad (5.6)$$

N_n^S is a normalizing constant given by:

$$N_n^S = (2\zeta)^{n+1/2} [(2n)!]^{-1/2} \quad (5.7)$$

Gaussian Type Orbitals are defined by the equations:

$$\chi_n^G = N_n^G r^{n-1} \exp(-\alpha r^2) \quad (5.8)$$

$$N_n^G = 2^{n+3/4} \alpha^{(2n+1)/4} \pi^{-1/4} [(2n-1)!]^{1/2} \quad (5.9)$$

Of these two types of orbitals the Slater functions are more convenient in describing atomic wave functions. A good approximation to the radial part of an atomic wave function can usually be obtained by the sum of a small number of Slater functions. To obtain the same accuracy with Gauss functions one needs an expansion of more terms. Notwithstanding this disadvantage Gauss functions are extensively used in molecular computations due to the fact that integrals involving this type of function are easier to calculate than the corresponding integrals over Slater functions. Most of the integrals needed in molecular calculations can be written in analytical form when one makes use of Gaussian functions (Shavitt, 1962). In calculating integrals over S.T.O.'s

one often has to use numerical integrations or expansion techniques (Harris and Michels, 1967).

Turning now to the calculation of the $f_{\mu\nu}$ matrix elements one can distinguish two different cases:

- (1) The orbitals χ_μ and χ_ν belong to the same atom. In this case analytical expressions for the matrix elements can be derived for both S.T.O.'s and G.T.O.'s.
- (2) The orbitals belong to different atoms. For this case analytical expressions have been derived for G.T.O.'s. For S.T.O.'s one has to use numerical integration (Bonham, 1965) or expansion techniques (Guerillot, Gana-chaud, Lissilour, 1968). The most convenient way at this moment seems to be the expansion of S.T.O.'s as a sum of a small number of G.T.O.'s as described by McWeeny (1953) and Stewart (1969b).

5.3 Calculation of scattering factors from Slater orbitals

As shown first by McWeeny (1951) analytical expressions for the scattering of an electron density described by a product of S.T.O.'s centered on the same atom can be derived. The scattering of a density involving p-orbitals is not only dependent on the length of the scattering vector s but also on the angle between the scattering vector and the symmetry axes of the p-orbitals. McWeeny (1951) demonstrated that the scattering factor of densities of this type may be described by two principal factors $f_{//}$ and f_{\perp} in which the vector s is parallel or perpendicular to the symmetry axes of the p-orbitals. The resulting scattering factor in the case that s has an arbitrary angle with the p-orbitals is a simple function of the principal factors and the angles between s and the p-orbital symmetry axis.

General formulae for the calculation of the principal scattering factors have been described (Harkema, 1970a). The formulae for the principal scattering factors $f_{\perp \mu\nu}$ and $f_{// \mu\nu}$ are given below. The μ and ν indices denote Slater Orbitals of s or p type with quantumnumbers n_1 and n_2 and coefficients ζ_1 and ζ_2 .

$$f_{ss} = N S_{n_1+n_2-1}(y)/y \quad (5.10)$$

$$f_{//sp} = i N [S_{n_1+n_2-2}(y)/y^2 - C_{n_1+n_2-1}(y)/y] \quad (5.11)$$

$$f_{\perp sp} = 0 \quad (5.12)$$

$$f_{//pp} = N [S_{n_1+n_2-1}(y)/y + 2C_{n_1+n_2-2}(y)/y^2 - 2S_{n_1+n_2-3}(y)/y^3] \quad (5.13)$$

$$f_{\perp pp} = N [S_{n_1+n_2-3}(y)/y^3 - C_{n_1+n_2-2}(y)/y^2] \quad (5.14)$$

The variable y and the constant N occurring in the formulae are given by

$$y = 4\pi \sin \theta / (\lambda (\zeta_1 + \zeta_2)) \quad (5.15)$$

$$N = 4\pi N_{n_1}^S N_{n_2}^S / (\zeta_1 + \zeta_2)^{n_1 + n_2 + 1} \quad (5.16)$$

(θ : diffraction angle, λ : wavelength of the radiation used).

The function $S_n(x)$ is defined by:

$$S_n(x) = \int_0^{\infty} t^n \exp(-t) \sin xt \, dt. \quad (5.17)$$

The function $C_n(x)$ is given by an integral similar to (5.17) in which the sine function in the integrand is replaced by a cosine function of the same argument. The integrals $S_n(x)$ and $C_n(x)$ can be calculated from recurrence relations which may be derived by partial integration of eq. 5.17 and the values of $S_0(x)$ and $C_0(x)$. For small values of n , $S_n(x)$ and $C_n(x)$ can also be obtained from explicit formulae derived from the recurrence relations.

The derivation of the equations for the scattering factors will be demonstrated for the $f_{//pp}$ factor. Inserting the proper expression for the atomic orbitals in (5.4) gives.

$$f_{//pp} = N_{n_1}^S N_{n_2}^S \int r^{n_1+n_2-4} \exp[-(\zeta_1 + \zeta_2)r + i\mathbf{s}\cdot\mathbf{r}] (\mathbf{i}\cdot\mathbf{r})^2 \, d\mathbf{r} \quad (5.18)$$

In this equation \mathbf{i} is a unit vector parallel to the symmetry axis of the p orbitals. Converting to polar coordinates (r, Θ, ϕ) yields:

$$f_{//pp} = N_{n_1}^S N_{n_2}^S \iiint r^{n_1+n_2} \exp[-(\zeta_1 + \zeta_2)r + isr \cos \Theta] \cos^2 \Theta \sin \Theta \, d\Theta \, d\phi \, dr \quad (5.19)$$

The integral is split into two parts by substituting:

$$\exp(isr \cos \Theta) = \cos(sr \cos \Theta) + i \sin(sr \cos \Theta) \quad (5.20)$$

After this substitution and integration over ϕ the real part of the scattering factor ($f_{//pp}^R$) is given by:

$$f_{//pp}^r = \int_0^{\infty} r^{n_1+n_2} \exp [-(\zeta_1+\zeta_2)r] dr \int_0^{\pi} \cos(sr \cos \Theta) \cos^2 \Theta \sin \Theta d\Theta \quad (5.21)$$

Integration over Θ (partial integration) gives as a result for the second integral of (5.21):

$$(2/sr)[\sin(sr) + 2 \cos(sr)/sr - 2 \sin(sr)/(sr)^2] \quad (5.22)$$

Taking as a variable y (defined in (5.15)) gives as the final expression for the real part of the scattering factor the formula given in (5.13).

The imaginary part of the scattering factor which results from substitution (5.20) is:

$$f_{//pp}^i = i \int_0^{\infty} r^{n_1+n_2} \exp [-(\zeta_1+\zeta_2)r] dr \int_0^{\pi} \sin(sr \cos \Theta) \cos^2 \Theta \sin \Theta d\Theta \quad (5.23)$$

As the integrand of (5.24) is an odd function with respect to $\Theta = \pi/2$ the imaginary part of the scattering factor is zero as required by the centrosymmetric charge distribution.

The formulae giving the scattering factor for orbital products involving p orbitals as a function of the angles (α or β) between the scattering vector s and the symmetry axes of the p orbitals are (Harkema, 1970^b):

$$f_{sp}(s) = f_{//sp} \cos \alpha \quad (5.24)$$

$$f_{p_1 p_2}(s) = f_{//p_1 p_2} \cos^2 \alpha + f_{\perp p_1 p_2} \sin^2 \alpha \quad (5.25)$$

when p_1 and p_2 have the same symmetry axis

$$f_{p_1 p_2}(s) = (f_{//p_1 p_2} - f_{\perp p_1 p_2}) \cos \alpha \cos \beta \quad (5.26)$$

when p_1 and p_2 have symmetry axes perpendicular to each other.

With the formulae given in this section the total scattering power of an atom can be calculated when the electronic configuration is known. The electronic configuration is fully specified by the values of the population coefficients $P_{\mu\nu}$ defined in eq. 5.3. In the one centre case the indices μ and ν denote orbitals which are centered on the same atom. The total number of electrons on an atom is given by the sum of the $P_{\mu\nu}$ terms (summed over all orbitals on the atom concerned). When dealing with one centre terms the wave function should be normalized in such a way that the sum of the $P_{\mu\nu}$ terms summed over all orbitals equals the total number of electrons in the molecule. Scattering factors for atoms which have no spherical symmetry (for

instance hybridized atoms in which different hybrids do not contain the same number of electrons) are easily constructed with the given formulae. The principal scattering factors may also be used to separate the scattering due to valence and core electrons. In the atoms C, N and O the 'core scattering' is caused by two 1s electrons. The 'valence scattering' depends on the 2s and 2p electrons. The scattering of the 2p electrons has to be spherically averaged which may be accomplished by taking:

$$\bar{f}_{pp} = \frac{1}{3} (f_{//pp} + 2 f_{\perp pp}) \quad (5.27)$$

In this way scattering factors for the core and valence electron distributions can be obtained.

A computer program – SCAT – has been written which calculates the different principal scattering factors for a given value of $|s|$. The values of these factors for the carbon, nitrogen and oxygen atom are given in tables 5.1, 5.2, and 5.3 respectively. In these tables the total scattering factor of the

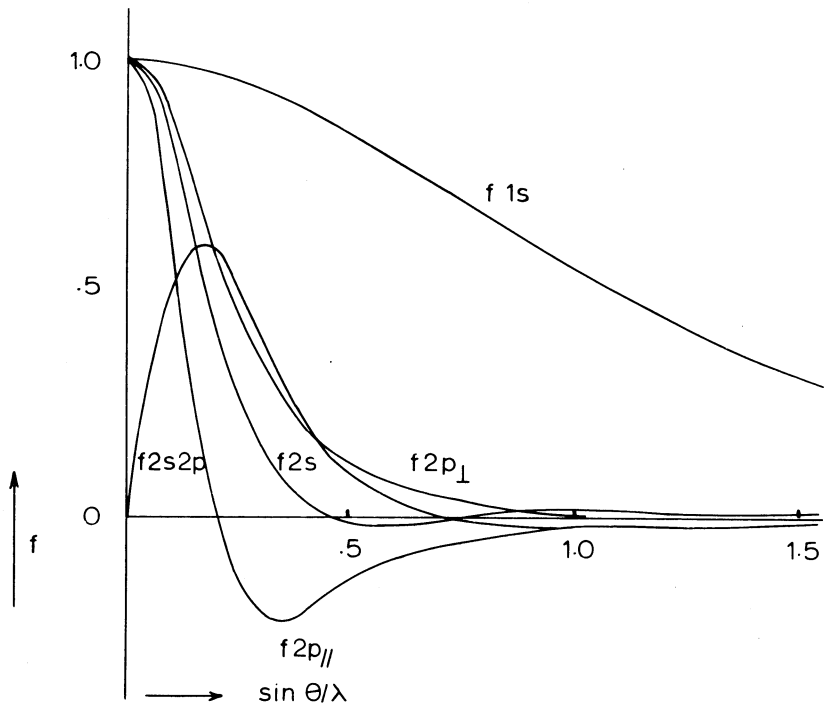

Figure 5.1

Different scattering factors for the carbon atom as a function of $\sin \theta/\lambda$

atom and the scattering factor of the core electrons are also given. The atomic wave functions used were the accurate atomic functions given by Clementi (1965). The behaviour of the different factors for the carbon atom is shown in figure 5.1. From this figure and the tables it is clear that for values of $\sin \theta/\lambda$ greater than .5 the scattering of the atom is almost exclusively due to the

$\sin \theta/\lambda$	f_{1s1s}	f_{2s2s}	$f_{//2p2p}$	$f_{\perp 2p 2p}$	f_{2s2p}	valence	total
.00	1.000	1.000	1.000	1.000	0.000	4.000	6.000
.05	.998	.946	.882	.960	.294	3.759	5.756
.10	.993	.802	.597	.854	.503	3.141	5.127
.15	.984	.614	.281	.715	.591	2.369	4.337
.20	.972	.428	.029	.573	.576	1.638	3.582
.25	.957	.271	-.131	.447	.502	1.051	2.964
.30	.939	.155	-.212	.343	.404	.625	2.502
.35	.918	.076	-.240	.261	.307	.340	2.176
.40	.895	.027	-.236	.199	.223	.160	1.950
.45	.870	-.001	-.217	.151	.155	.005	1.795
.50	.843	-.014	-.192	.116	.103	-.002	1.684
.55	.815	-.018	-.166	.089	.065	-.028	1.602
.60	.786	-.017	-.141	.069	.036	-.036	1.536
.65	.756	-.013	-.119	.053	.017	-.034	1.478
.70	.726	-.008	-.099	.042	.003	-.027	1.425
.75	.695	-.003	-.083	.033	-.006	-.018	1.373
.80	.665	.001	-.069	.026	-.012	-.008	1.321
.85	.635	.005	-.058	.021	-.016	.000	1.270
.90	.605	.009	-.048	.017	-.017	.008	1.217
.95	.576	.011	-.040	.014	-.018	.014	1.165
1.00	.547	.013	-.034	.011	-.018	.019	1.113
1.05	.519	.015	-.028	.009	-.018	.023	1.061
1.10	.493	.016	-.024	.008	-.017	.026	1.011
1.15	.467	.016	-.020	.006	-.016	.028	.961
1.20	.442	.017	-.017	.005	-.015	.029	.913
1.25	.418	.017	-.015	.004	-.014	.029	.866
1.30	.395	.016	-.013	.004	-.013	.030	.820
1.35	.374	.016	-.011	.003	-.012	.029	.777
1.40	.353	.016	-.009	.003	-.011	.029	.735
1.45	.334	.015	-.008	.002	-.010	.028	.695
1.50	.315	.015	-.007	.002	-.009	.027	.657
1.55	.297	.014	-.006	.002	-.008	.026	.621

Table 5.1

Different atomic form factors for the carbon atom.

scattering of the core electrons. The contribution of the valence electrons which dominates the atomic scattering factor at small values of $\sin \theta/\lambda$ is seen to decrease rapidly with increasing $\sin \theta/\lambda$.

$\sin \theta/\lambda$	f_{1s1s}	f_{2s2s}	$f_{//2p2p}$	$f_{\perp 2p2p}$	f_{2s2p}	valence	total
.00	1.000	1.000	1.000	1.000	.000	5.000	7.000
.05	.999	.961	.919	.937	.249	4.787	6.784
.10	.995	.855	.709	.897	.445	4.214	6.204
.15	.988	.707	.447	.791	.560	3.444	5.421
.20	.980	.546	.202	.674	.594	2.641	4.600
.25	.968	.395	.011	.599	.566	1.920	3.857
.30	.955	.268	-.117	.456	.501	1.332	3.242
.35	.940	.169	-.192	.369	.421	.883	2.762
.40	.922	.097	-.228	.296	.340	.557	2.402
.45	.903	.047	-.238	.237	.265	.331	2.137
.50	.883	.015	-.231	.190	.201	.179	1.944
.55	.861	-.004	-.216	.152	.147	.081	1.802
.60	.838	-.013	-.196	.122	.105	.021	1.696
.65	.814	-.017	-.175	.099	.071	-.012	1.615
.70	.789	-.017	-.155	.080	.045	-.028	1.549
.75	.763	-.014	-.135	.065	.025	-.034	1.493
.80	.738	-.010	-.117	.053	.011	-.032	1.443
.85	.712	-.006	-.102	.043	.000	-.027	1.396
.90	.686	-.002	-.008	.036	-.007	-.020	1.351
.95	.660	.002	-.076	.029	-.012	-.013	1.307
1.00	.634	.006	-.065	.024	-.016	-.005	1.263
1.05	.609	.009	-.056	.020	-.018	.001	1.219
1.10	.584	.010	-.049	.017	-.019	.008	1.175
1.15	.559	.013	-.042	.014	-.020	.013	1.132
1.20	.536	.015	-.037	.012	-.020	.017	1.088
1.25	.512	.016	-.032	.010	-.019	.021	1.045
1.30	.490	.017	-.028	.009	-.019	.023	1.003
1.35	.468	.017	-.024	.007	-.018	.025	.961
1.40	.446	.018	-.021	.006	-.017	.027	.920
1.45	.426	.018	-.018	.006	-.016	.028	.880
1.50	.406	.018	-.016	.005	-.015	.029	.841
1.55	.387	.017	-.014	.004	-.014	.029	.804

Table 5.2

Different atomic form factors for the nitrogen atom.

5.4 Calculation of scattering factors from Gauss orbitals

When dealing with Gauss functions analytical expressions for the scattering factor may be derived in both the one and two center cases. In the derivation of the formulae one makes use of the integral:

$\sin \theta/\lambda$	f_{1s1s}	f_{2s2s}	$f_{//2p2p}$	$f_{\perp 2p2p}$	f_{2s2p}	valence	total
.00	1.000	1.000	1.000	1.000	.000	6.000	8.000
.05	.999	.971	.937	.979	.216	5.801	7.799
.10	.996	.891	.768	.919	.397	5.257	7.249
.15	.991	.774	.547	.832	.520	4.497	6.479
.20	.985	.638	.323	.733	.580	3.662	5.631
.25	.976	.501	.133	.631	.585	2.862	4.815
.30	.966	.376	-.013	.535	.551	2.162	4.093
.35	.954	.268	-.113	.449	.494	1.584	3.492
.40	.940	.182	-.176	.375	.427	1.128	3.008
.45	.925	.115	-.211	.311	.358	.779	2.630
.50	.909	.066	-.226	.258	.292	.520	2.338
.55	.892	.032	-.227	.214	.233	.332	2.115
.60	.873	-.009	-.220	.178	.182	.199	1.945
.65	.854	-.005	-.207	.147	.139	.107	1.814
.70	.833	-.013	-.191	.123	.104	.046	1.713
.75	.812	-.016	-.175	.102	.075	.008	1.632
.80	.791	-.016	-.158	.086	.051	-.015	1.567
.85	.769	-.015	-.142	.072	.033	-.027	1.511
.90	.747	-.012	-.127	.060	.018	-.031	1.462
.95	.724	-.008	-.113	.051	.007	-.031	1.417
1.00	.702	-.005	-.099	.043	-.001	-.027	1.376
1.05	.679	-.001	-.088	.036	-.008	-.022	1.336
1.10	.657	.002	-.078	.031	-.012	-.017	1.297
1.15	.634	.006	-.069	.026	-.016	-.010	1.258
1.20	.612	.008	-.061	.023	-.018	-.004	1.220
1.25	.590	.011	-.054	.019	-.019	.001	1.182
1.30	.569	.013	-.048	.017	-.020	.006	1.144
1.35	.548	.014	-.042	.014	-.020	.011	1.106
1.40	.527	.016	-.037	.013	-.020	.015	1.069
1.45	.507	.017	-.033	.011	-.020	.018	1.032
1.50	.487	.017	-.029	.009	-.019	.021	.996
1.55	.468	.018	-.026	.008	-.019	.023	.960

Table 5.3
Different atomic form factors for the oxygen atom.

$$\int \exp(-\alpha |\mathbf{r}|^2 + \mathbf{p} \cdot \mathbf{r}) \, d\mathbf{r} = \pi^{3/2} \alpha^{-3/2} \exp(-|\mathbf{p}|^2/4\alpha) \quad (5.28)$$

This result is also valid when \mathbf{p} is a complex quantity.

The coordinate system used in the two center case is given in figure 5.2. The scattering factor for the product of two 1s orbitals of which one is on center A and the other on center B is given by:

$$f_{1s1s} = N \int \exp(-\alpha |\mathbf{r}_a|^2 - \beta |\mathbf{r}_b|^2 + i \mathbf{s} \cdot \mathbf{r}) \, d\mathbf{r} \quad (5.29)$$

In this expression N is a normalizing constant consisting of the product of the normalizing constants of the separate orbitals as given in eq. 5.7. Introduction of the expressions for \mathbf{r}_a and \mathbf{r}_b in terms of \mathbf{a}, \mathbf{b} , and \mathbf{r} leads to the equation:

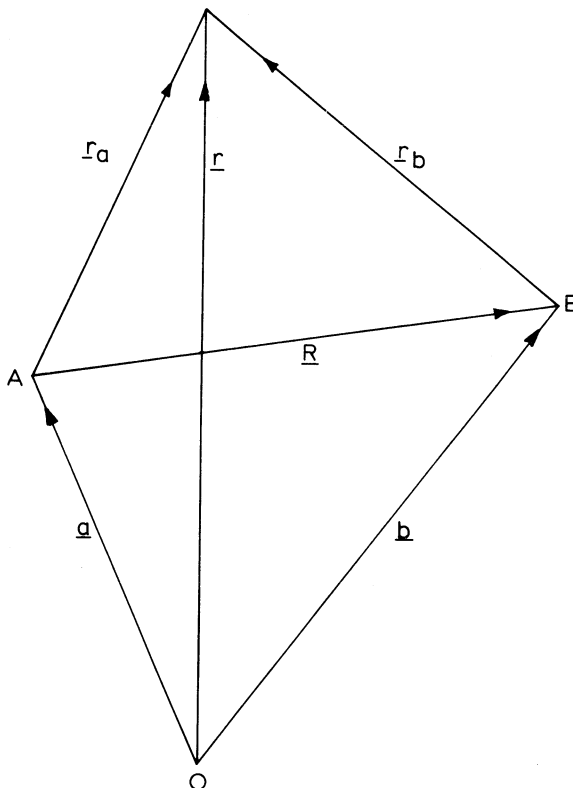

Figure 5.2

The coordinate system used in the calculations of two center scattering factors. The origin is denoted by O

$$f_{1s1s} = N \int \exp [-(\alpha + \beta) | \mathbf{r} |^2 + (2\alpha\mathbf{a} + 2\beta\mathbf{b} + i\mathbf{s}) \cdot \mathbf{r}] d\mathbf{r} \quad (5.30)$$

Applying eq. 5.28 gives:

$$f_{1s1s} = N \pi^{3/2} (\alpha + \beta)^{-3/2} \exp [(-4\alpha\beta (a-b)^2 + 4i\mathbf{s} \cdot (\alpha\mathbf{a} + \beta\mathbf{b}) - |\mathbf{s}|^2)/4(\alpha + \beta)] \quad (5.31)$$

Scattering factors for s orbitals with quantum numbers $n = 3, 5, 7 \dots$ can be obtained from the 1s, 1s scattering factors (5.31) by (repeated) differentiation with respect to α or β . Scattering factors for p_x, p_y and p_z orbitals can be calculated from (5.31) by differentiation with respect to s_x, s_y and s_z respectively (Groenewegen and Feil, 1969). Differentiations have to be carried out after the origin has been moved to the point on which the orbital concerned is centered.

In this way the following expressions for the scattering factors of 1s and 2p orbitals have been derived. The origin of the coordinate system is taken in the midpoint of the bond.

$$f_{1s1s} = 2^{3/2} (\alpha\beta)^{3/4} (\alpha + \beta)^{-3/2} \exp [-\mathbf{A}_a \cdot \mathbf{A}_b / (\alpha + \beta)] \quad (5.32)$$

$$f_{1s2p} = -2\beta^{1/2} (\alpha + \beta)^{-1} (\mathbf{P}_b \cdot \mathbf{A}_a) f_{1s1s} \quad (5.33)$$

$$f_{2p2p} = 2(\alpha\beta)^{1/2} (\alpha + \beta)^{-1} [\mathbf{P}_a \cdot \mathbf{P}_b - 2(\mathbf{P}_a \cdot \mathbf{A}_b)(\mathbf{P}_b \cdot \mathbf{A}_a)(\alpha + \beta)^{-1}] f_{1s1s} \quad (5.34)$$

In those formulae \mathbf{A}_a and \mathbf{A}_b are given by:

$$\mathbf{A}_a = \alpha\mathbf{R} - i\mathbf{s}/2 \quad (5.35)$$

$$\mathbf{A}_b = \beta\mathbf{R} + i\mathbf{s}/2 \quad (5.36)$$

\mathbf{P}_a and \mathbf{P}_b are unit vectors parallel to the symmetry axes of the p orbitals. Equations 5.32 to 5.34 are similar to those given by Stewart (1969^b).*)

A computer program - GAUSS - has been made by which the scattering factors for the different orbital products can be calculated. The orbitals used in the computations are the three term G.T.O. expansions of atomic orbitals given by Stewart (1969^a). The input of the program consists of the atomic

*) The equations derived by Stewart contain a sign error. This mistake has been carried over in some of his calculations. Therefore not all scattering factor curves given in his article are correct.

numbers of the atoms and the quantum numbers necessary to specify the type of the orbitals for which the scattering factors have to be calculated. The rest of the input contains information concerning the vectors \mathbf{s} , \mathbf{R} , \mathbf{P}_a , and \mathbf{P}_b . With help of this program a number of scattering factor curves have been calculated, examples of which are given in figures 5.3 and 5.4. The two-center curves indicate that the importance of valence electron scattering rapidly decreases with increasing $\sin \theta/\lambda$. The same result was found in the one center case.

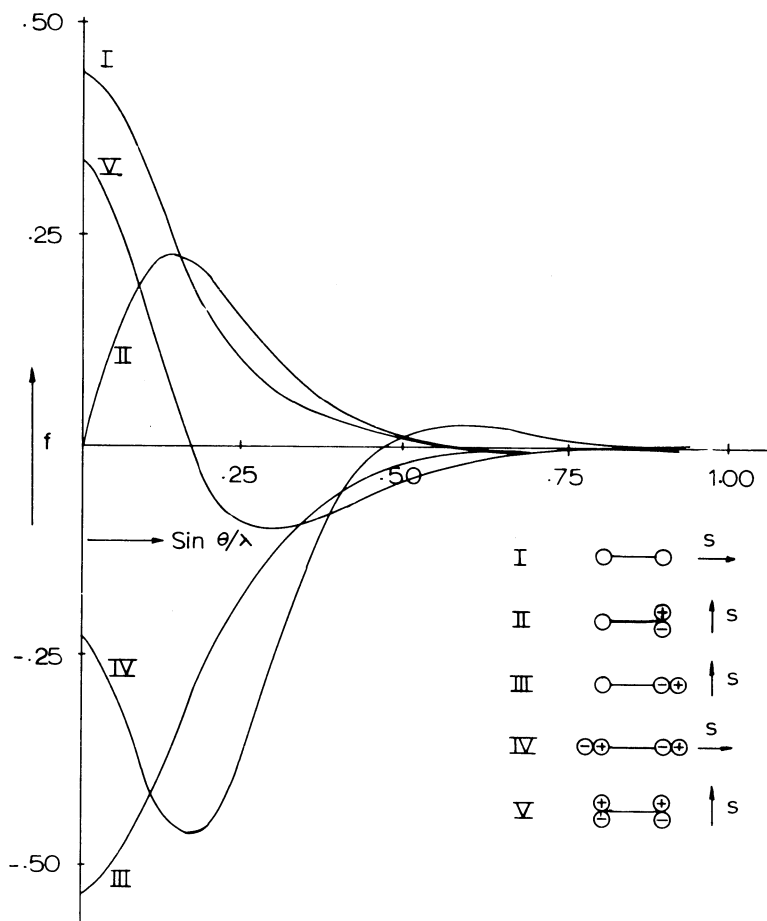

Figure 5.3

Scattering factors for two-center $2s$ and $2p$ orbital products. All factors are calculated for two carbon atoms at a distance of 1.35\AA . The factors are real, except for II which is imaginary.

5.5 Determination of the number of valence electrons

As described in section 5.3 it is possible to calculate separately the scattering factors of the valence and core electron densities for the different atoms. These scattering factors do not include any effect of chemical bonding. They are calculated normally for atoms in their ground state. This separation of scattering factors makes it possible to estimate the number of valence electrons on the different atoms in a crystal structure.

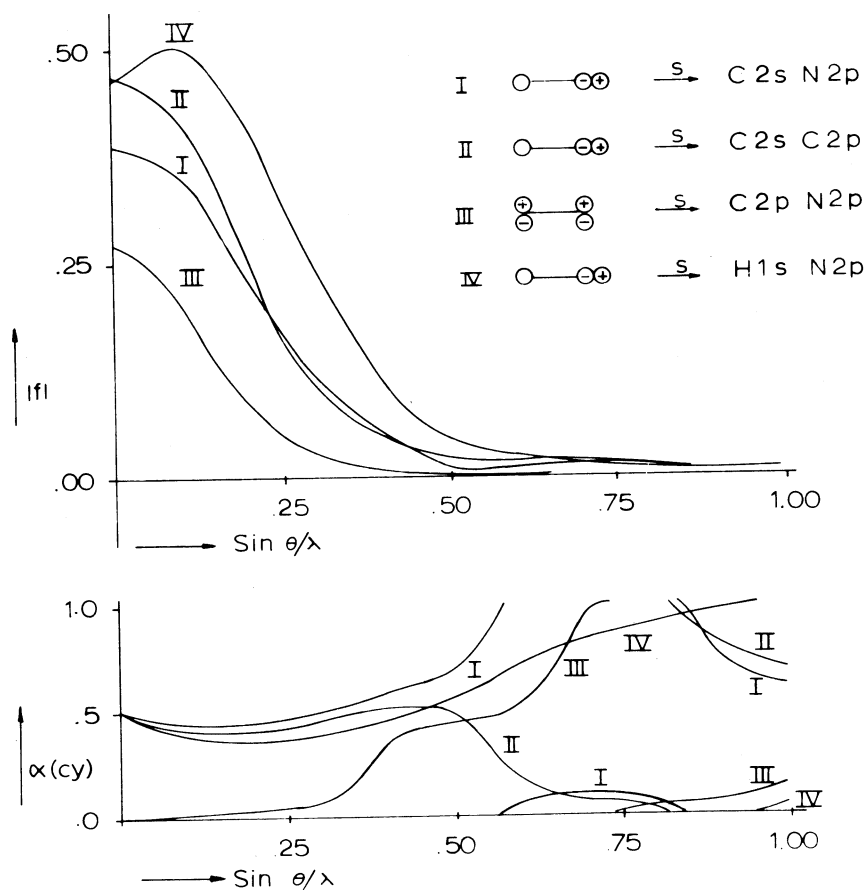

Figure 5.4

Complex scattering factors of some orbital products. The absolute value of the scattering factor and the phase angle (in cycles) are given. The distances used in the calculations are C-C: 1.35 Å, C-N: 1.37 Å, and H-N: .91 Å

This can be accomplished by replacing each atom for which the number of valence electrons is to be determined by two hypothetical atoms. The first 'atom' consists of the core electrons. The second 'atom' contains the valence electrons. The number of valence electrons can be determined by refining in the least-squares procedure an occupancy factor for each 'valence-electron atom'. In these calculations one uses the mean scattering factor of a 2s and 2p electron density. As differences between the 2s and 2p electron density scattering factors of the same atom are small, no serious errors are introduced. The procedure outlined has as a disadvantage that there is a strong correlation between different parameters which are refined simultaneously. Strong correlations are expected between thermal parameters, occupancy factors and the scale factor*. To overcome these difficulties one has to fix a number of parameters. This can be done for instance by using positional and thermal parameters which have been obtained from refinement of data collected in that part of reciprocal space where the influence of valence electron scattering is small ($\sin \theta/\lambda > .5$). Another way is to fix positional and thermal parameters at the values resulting from a neutron diffraction study on the same compound. The latter procedure has been adopted in our work. Parameters have been taken from the work of Worsham and Busing (1969). Numbers of valence electrons for the atoms in uronium nitrate determined in this way are displayed in table 5.4, column a. The values have been obtained by refining the number of valence electrons (the number of core electrons for the heavy atoms was 2) and a scale factor. The resulting R-factor in this case - 4.8% - is significantly better than the value found by using the 'standard' number of valence electrons ($R = 5.7\%$, section 3.3.).

	a	b	c		a	b	c
C	3.97(8)	3.84(8)	3.45	O(4)	6.45	6.24	6.21
N(1)	4.74	4.58	4.39	H(1)	.72(5)	.70(5)	.78
N(2)	5.63	5.44	5.22	H(2)	.82	.79	.79
N(3)	5.43	5.25	5.23	H(3)	.67	.65	.79
O(1)	6.42	6.21	6.54	H(4)	.82	.79	.79
O(2)	6.63	6.41	6.54	H(5)	.87	.84	.68
O(3)	6.48	6.26	6.54				

Table 5.4.

Number of valence electrons for the different atoms in uronium nitrate. a: determined by X-ray diffraction; b: X-ray results after renormalization (see text); c: calculated by the C.N.D.O./2 method.

*) The factor by which calculated structure factors have to be multiplied to be on the same scale as the experimental ones. Measurements on an absolute scale are difficult to perform in single-crystal diffractometry.

	P_{1s1s}	P_{2s2s}	$P_{2p_x 2p_x}$	$P_{2p_y 2p_y}$	$P_{2p_z 2p_z}$	$P_{2s 2p_x}$	$P_{2s 2p_y}$	$P_{2p_x 2p_y}$
C	2.000	.992	.898	.886	.691	.004	.008	.011
N(1)	2.000	1.302	1.122	1.134	.860	.062	.017	.018
N(2)	2.000	1.190	1.127	1.161	1.743	.063	-.025	.015
N(3)	2.000	1.207	1.145	1.152	1.684	-.069	-.063	.004
O(1)	2.000	1.814	1.892	1.106	1.721	.128	-.405	.275
O(2)	2.000	1.790	1.143	1.941	1.617	-.423	.086	.170
O(3)	2.000	1.842	1.589	1.325	1.803	.251	.323	-.510
O(4)	2.000	1.654	1.472	1.194	1.882	-.386	.167	.051
H(1)	.79	—	—	—	—	—	—	—
H(2)	.79	—	—	—	—	—	—	—
H(3)	.79	—	—	—	—	—	—	—
H(4)	.79	—	—	—	—	—	—	—
H(5)	.75	—	—	—	—	—	—	—

table 5.5

Elements of the charge-bond order matrix used in the calculations with aspherical scattering factors.

It is interesting that the redistribution of electrons over the different atoms gives also a better comparison in the X-ray results. If a refinement is made using atomic scattering factors based on electron densities obtained by the C.N.D.O./2 method, the resulting R-factor is 3.8%. The corresponding R-factor calculated with neutral atoms was 4.1% (section 2.5).

The method described is not correct in so far that the total number of valence electrons is not a fixed number in the refinement. In order to correct more or less this effect we have renormalized the number of valence electrons in such a way that the total number of valence electrons equals 48.

The number of electrons after renormalization are given in table 5.4 column b. The table also shows the number of valence electrons calculated by the C.N.D.O./2 method (chapter IV). Inspection of the table reveals that the number of electrons of chemically equivalent atoms are close to each other. Comparison of experimental and calculated numbers shows a fair agreement. The total number of valence electrons for the uronium ion is 24.5, for the nitrate ion 23.5. The 'theoretical' number of valence electrons is 24 for each ion, assuming complete ionization.

The method described in this section is very similar to the (Extended) L-shell Projection Method described recently by Stewart (1970) and Coppens, Pautler and Griffin (1971).

5.6 Calculations with scattering factors based on aspherical electron densities

The electron density in a molecule can be described by the charge-bond order matrix defined in equation 4.11. The elements of this matrix can, in principle, be determined from a combined X-ray and neutron diffraction experiment. The charge-bond order matrix is not unique: the matrix depends on the choice of basis orbitals. The formalism for the determination of the matrix elements from diffraction experiments has been given by Coppens, Willoughby and Csonka (1971). Application of the method to molecules of the size of uronium nitrate, however, is very troublesome because of the large number of matrix elements to be determined and the strong correlations which exist between some matrix elements.

In uronium nitrate we therefore used a much simpler method. The charge-bond order matrix (population matrix) was computed by the C.N.D.O./2 method. The axes taken as the x, y and z axis in the quantumchemical calculations were the **a**, **b**, and **c*** crystallographic axes. The uronium and nitrate ions were assumed to be planar. The plane of the molecule was supposed to be perpendicular to the **c*** axis (z axis of the molecular system). The orientation of the ions with respect to the **a** and **b** axes was taken from the X-ray experiment. The calculations were restricted to a one-center model: all matrix

elements between functions centered on different atoms were assumed to be zero. The elements of the population matrix which have been used in the calculations are given in table 5.5 (p. 69). As the molecule is planar all bond orders involving the p_z orbital are zero.

The least-squares program (section 2.7) was modified in order to calculate structure factors based on aspherical electron densities. The input of the program includes (besides the normal input of the least-squares program) the population matrix elements of the molecule to be calculated. In the program a provision is made to take into account the scattering of the symmetry-related molecules in the unit cell.

A calculation of structure factors using neutron values for the positional and thermal parameters gave an R-value of 6.6%. The regions in which appreciable differences between observed and calculated electron densities exist are evident from figure 5.5, which shows a difference Fourier-synthesis map made at this stage of the investigation. Comparison of this map with the one shown in figure 3.2.b shows that the model used gives a good description of the electron density in the regions of the lone-pair electrons. In the regions of the bonding electrons, however, large discrepancies between observed and calculated electron densities exist. This can be expected because of the fact that the two-center terms, which are neglected, play an important role in the description of the overlap density. To get a proper description of the electron density one has to incorporate these two-center terms in the calculations.

A surprising result is that refinement of positional and thermal parameters, using the model described in this section, gave an R-factor of 4.2%: nearly as good as the result of a 'normal' refinement (4.1%). The resulting positional parameters show appreciable differences from the neutron values. Inspection of table 5.6, which shows the resulting positional parameters, reveals that the atoms are shifted towards the bonding region to compensate the excess electron density. This shift is demonstrated also in table 5.7 (p.74), which gives bond distances in the nitrate ion determined with different models.

A tentative conclusion is that the model based on spherical atoms contains mutually compensating errors, one of which is removed by the use of scattering factors based on aspherical atoms. This conclusion is supported by the difference electron density maps, in which we observe an improvement in regions that depend mainly on one atom (lone-pair regions). An increased difference is found at the same time between observed and calculated densities in the bonding regions.

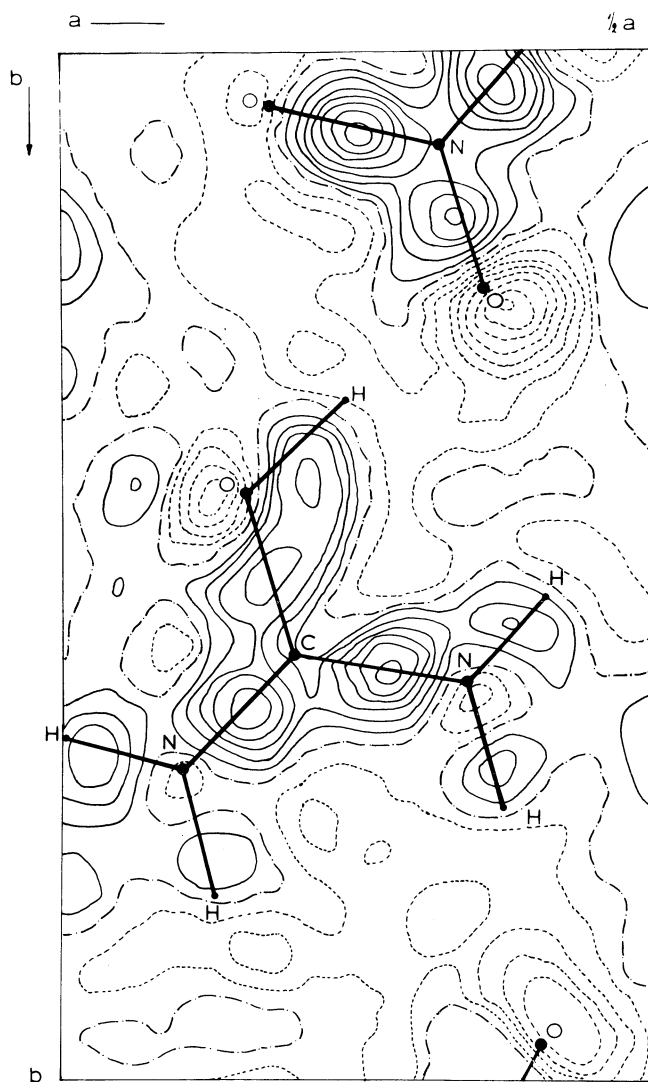

Figure 5.5

Fourier synthesis map ($z/c = .25$) showing the difference between observed and calculated electron density. The calculated density is based on aspherical atoms. Interval between two contour lines: $.05 e \text{ \AA}^{-3}$.

	x/a			y/b			z/c		
	a	b	c	a	b	c	a	b	c
C	.1978	.1981	.1976	.4102	.4105	.4111	.2557	.2258	.2548
N(1)	.3109	.3112	.3113	.9166	.9171	.9167	.2544	.2542	.2541
N(2)	.3330	.3334	.3345	.3776	.3767	.3767	.2602	.2605	.2612
N(3)	.1015	.1010	.1013	.2967	.2963	.2960	.2538	.2537	.2542
O(1)	.3512	.3521	.3525	.7749	.7723	.7727	.2493	.2493	.2500
O(2)	.1899	.1871	.1883	.9453	.9460	.9460	.2602	.2602	.2608
O(3)	.3952	.3969	.3964	.0277	.0297	.0292	.2517	.2517	.2513
O(4)	.1516	.1497	.1501	.5595	.5613	.5605	.2483	.2484	.2489

Table 5.6

Positional parameters for the heavy atoms in uronium nitrate with scattering factors based on: a: aspherical-atoms, b: spherical atoms (chapter II), c: neutron results (Worsham and Busing (1969)).

	a	b	c
N(1) – O(1)	1.231(4)	1.256(4)	1.250(1)
N(1) – O(2)	1.202	1.233	1.227
N(1) – O(3)	1.222	1.242	1.236

Table 5.7.

Bond lengths (\AA) for the nitrate ion determined with different models
a: aspherical atoms
b: spherical atoms (chapter II)
c: neutron values.

5.7 Literature

- BONHAM, R.A. (1965). *J. Phys. Soc. Japan*, **20**, 2260.
 CLEMENTI, E. (1965). *I.B.M. Journal* **9**, 12.
 COPPENS, P., WILLOUGHBY, T.V. and CSONKA, L.N. (1971). *Acta Cryst.* **A27**, 248.
 COPPENS, P., PAUTLER, D. and GRIFFIN, J.F. (1971). *J. Amer. Chem. Soc.* **93**, 1051.
 EYRING, H., WALTER, J. and KIMBALL, G.E. (1944). *Quantum Chemistry*, Wiley, New York.
 GROENEWEGEN, P.P.M. and FEIL, D. (1969). *Acta Cryst.* **A25**, 444.
 GUERILLOT, G.R., GANACHAUD, J.P. and LISSILOUR, R. (1968). *Theor. Chim. Acta* **9**, 230.
 HARKEMA, S. (1970^a). Progress Report, *Chem. Phys. Lab.*, Twente University of Technology, C18.
 HARKEMA, S. (1970^b). *ibid.*, C24.
 HARRIS, F.E. and MICHELS, H.H. (1967). *Adv. in Chem. Phys.*, **13**, 205.
 JAMES, R.W. (1948). *The optical Principles of the Diffraction of X-rays*, Bell, London.
 McWEENY, R. (1951). *Acta Cryst.* **4**, 513.
 McWEENY, R. (1953). *ibid.* **6**, 631.
 SHAVITT, I. (1962). *Methods in Computational Physics*, vol 2, Academic Press, New York.
 STEWART, R.F. (1969^a). *J. Chem. Phys.* **50**, 2485.
 STEWART, R.F. (1969^b). *ibid.* **51**, 4569.
 STEWART, R.F. (1970). *ibid.* **53**, 205.
 WORSHAM, J.E. and BUSING, W.R. (1969). *Acta Cryst.* **B25**, 572.

SAMENVATTING

Dit proefschrift beschrijft onderzoeken naar de moleculaire en electronen structuur van uronium nitraat met behulp van röntgendiffractie. De verkregen resultaten worden, waar mogelijk, vergeleken met theoretische resultaten.

Hoofdstuk I geeft een kort overzicht van de twee belangrijkste aspecten van het werk: de bepaling van electronendichtheden door middel van diffractietechnieken en gegevens over de moleculaire structuren van zouten van ureum.

Hoofdstuk II beschrijft de structuurbepaling van uronium nitraat. De verbinding bestaat uit uronium en nitraat ionen verbonden door een tweedimensionaal netwerk van waterstofbruggen. Het 'extra' proton van het uronium ion bevindt zich aan het zuurstofatoom.

Hoofdstuk III geeft een overzicht van de verschillen die verwacht kunnen worden bij vergelijking van resultaten van röntgen en neutronendiffractie onderzoek aan dezelfde kristalstructuur. Deze verschillen hangen samen met het feit dat met röntgendiffractie het 'zwaartepunt' van de elektronenverdeling rond de atomen wordt bepaald. Neutronendiffractie daarentegen levert gegevens over plaats en beweging van de atoomkern. De (relatief kleine) verschillen die bestaan tussen de resultaten van het in hoofdstuk II beschreven structuuronderzoek en een recent gepubliceerd onderzoek met neutronen, kunnen hiermede grotendeels verklaard worden. Door combinatie van röntgen en neutronengegevens ontstaat de mogelijkheid om ladingsverschuivingen ten gevolge van chemische binding zichtbaar te maken. De grootste verschillen treden op op plaatsen die voorspeld kunnen worden met eenvoudige modellen voor de chemische binding.

Hoofdstuk IV geeft de resultaten van semi-empirische quantumchemische berekeningen (C.N.D.O./2) aan uronium nitraat en verwante verbindingen. Het blijkt dat bindingshoeken in het ureum molecule en het uronium ion redelijk goed berekend kunnen worden. Bij de bindingslengten in het nitraat en uronium ion wordt een relatie tussen bindingslengten en sterkte van de waterstofbruggen gevonden. Een en ander wordt bevestigd door resultaten van structuuronderzoekingen aan verwante verbindingen.

Hoofdstuk V beschrijft berekeningen waarbij gebruik gemaakt wordt van verschillende modellen voor het verstrooiend vermogen van röntgenstraling. Deze verbeterde modellen zijn nodig omdat het 'klassieke' model (bolvormige electronendichtheid voor alle atomen) voor nauwkeurige bepalingen niet voldoet. De berekening van verstrooiende vermogens uit verschillende (electronen)-golffuncties wordt beschreven. Gebruikmakend van de neutronen gegevens kan het aantal valentie-electronen bij ieder atoom bepaald worden. De verkregen getallen zijn in redelijke overeenstemming met theoretische waarden.

APPENDIX I

Observed and calculated structure factors (multiplied by 10) for uronium nitrate. The values given are: h, k, l, absolute value of observed and calculated structure factor.

0	1	1	1	5	-1	1	6	11	6	1	6	5	27	21	2	3	2	283	280
0	1	2	20	23	-1	1	6	2	7	-1	6	6	13	17	2	3	3	34	34
0	1	3	1	7	-1	1	7	11	10	-1	7	0	16	15	-2	3	3	33	33
0	1	4	23	18	-1	2	0	41	49	1	7	0	13	15	-2	3	4	260	253
0	1	5	2	0	-1	2	0	39	49	1	7	1	43	34	2	3	4	88	87
0	1	6	9	10	-1	2	1	18	20	-1	7	1	54	44	-2	3	5	15	13
0	1	7	2	2	-1	2	1	74	74	-1	7	2	17	15	2	3	5	19	12
0	2	0	343	353	-1	2	2	44	49	-1	7	3	30	27	-2	3	6	75	70
0	2	1	565	603	-1	2	2	13	20	1	7	3	8	8	2	3	6	16	18
0	2	2	257	250	-1	2	3	21	25	-1	7	4	10	12	-2	3	7	2	3
0	2	3	295	297	-1	2	3	61	58	1	7	4	16	8	2	4	0	142	141
0	2	4	115	110	-1	2	4	24	29	-1	7	5	15	8	-2	4	0	146	141
0	2	5	116	116	-1	2	4	1	6	1	8	0	125	124	-2	4	1	243	245
0	2	6	40	41	-1	2	5	23	26	-1	8	0	128	124	2	4	1	203	198
0	2	7	46	46	-1	2	5	33	28	-1	8	1	68	65	2	4	2	86	85
0	3	1	15	21	-1	2	6	6	2	1	8	1	63	60	-2	4	2	151	147
0	3	2	1	6	-1	2	6	2	14	1	8	2	89	88	-2	4	3	170	167
0	3	3	28	32	-1	2	7	9	16	-1	8	2	113	114	2	4	3	99	102
0	3	4	2	1	-1	3	0	94	97	-1	8	3	35	40	2	4	4	38	42
0	3	5	22	18	-1	3	0	96	97	1	8	3	33	35	-2	4	4	102	97
0	3	6	11	3	-1	3	1	230	228	-1	8	4	74	69	-2	4	5	85	78
0	3	7	18	7	-1	3	1	264	262	-1	9	0	33	30	2	4	5	46	44
0	4	0	110	105	-1	3	2	65	69	1	9	0	32	30	-2	4	6	54	50
0	4	1	138	127	-1	3	2	63	62	1	9	1	24	6	-2	4	7	29	38
0	4	2	66	67	-1	3	3	100	104	-1	9	1	17	5	-2	5	0	94	91
0	4	3	64	67	-1	3	3	154	151	-1	9	2	30	32	2	5	0	97	91
0	4	4	16	11	-1	3	4	15	22	1	9	2	24	17	2	5	1	123	128
0	4	5	13	16	-1	3	4	15	18	-1	9	3	15	5	-2	5	1	168	164
0	4	6	3	10	-1	3	5	38	37	2	0	4	288	294	-2	5	2	100	99
0	5	1	1	2	-1	3	5	55	58	2	0	4	103	107	2	5	2	37	41
0	5	2	6	9	-1	3	6	6	0	-2	0	4	272	278	2	5	3	52	55
0	5	4	21	7	-1	3	6	2	0	2	0	6	35	40	-2	5	3	111	109
0	5	5	10	5	-1	3	7	26	19	-2	0	8	35	38	-2	5	4	54	55
0	5	6	18	2	-1	4	0	71	77	-2	1	0	203	214	2	5	4	8	8
0	6	0	282	279	-1	4	0	76	77	2	1	0	202	214	-2	5	5	32	37
0	6	2	226	221	-1	4	1	38	36	2	1	1	347	344	2	5	5	2	14
0	6	3	22	19	-1	4	1	1	10	-2	1	1	452	453	-2	5	6	17	16
0	6	4	123	123	-1	4	2	29	35	-2	1	2	209	209	-2	5	7	12	2
0	6	5	15	16	-1	4	2	76	76	2	1	2	115	109	2	6	0	197	192
0	7	1	2	3	-1	4	3	35	38	2	1	3	160	163	-2	6	0	197	192
0	7	3	5	6	-1	4	4	34	42	-2	1	3	310	311	2	6	1	2	7
0	7	4	2	6	-1	4	4	2	3	-2	1	4	106	106	2	6	2	132	131
0	7	5	10	3	-1	4	5	6	4	2	1	4	41	43	-2	6	2	192	185
0	8	0	115	104	-1	4	5	16	24	-2	1	5	140	143	-2	6	3	33	26
0	8	1	236	234	-1	4	6	2	4	2	1	5	61	64	2	6	3	15	8
0	8	2	92	86	-1	4	6	14	18	-2	1	6	43	44	-2	6	4	120	110
0	8	3	160	165	-1	4	7	2	3	2	1	6	15	16	2	6	4	67	69
0	8	4	48	50	-1	5	0	303	295	-2	1	7	56	60	-2	6	5	29	29
0	9	1	10	5	-1	5	0	303	295	-2	1	8	16	19	-2	6	6	59	60
0	9	2	8	2	-1	5	1	123	118	2	2	0	213	212	-2	7	0	152	151
1	0	0	69	64	-1	5	1	143	139	-2	2	0	211	212	2	7	0	145	151
-1	0	0	69	64	-1	5	2	251	246	-2	2	1	311	346	2	7	1	183	193
-1	0	2	95	99	-1	5	2	196	193	2	2	1	253	252	-2	7	1	213	222
-1	0	2	25	31	-1	5	3	58	62	2	2	2	112	115	-2	7	2	152	155
-1	0	4	54	52	-1	5	3	98	95	-2	2	2	200	198	2	7	2	88	93
-1	0	4	41	45	-1	5	4	123	120	-2	2	3	243	235	-2	7	3	169	173
-1	0	6	26	30	-1	5	4	75	77	2	2	3	117	116	2	7	3	116	118
-1	0	6	24	19	-1	5	5	41	45	2	2	4	48	46	-2	7	4	98	103
-1	1	0	72	66	-1	5	5	25	26	-2	2	4	106	100	2	7	4	45	41
1	1	0	73	66	-1	5	6	38	42	-2	2	5	108	106	-2	7	5	96	99
1	1	1	44	44	-1	6	0	14	18	2	2	5	47	48	2	8	0	31	33
-1	1	1	42	38	-1	6	0	12	18	-2	2	6	38	41	-2	8	0	33	33
-1	1	2	44	44	-1	6	1	99	102	2	2	6	15	17	-2	8	1	51	48
1	1	2	39	46	-1	6	1	83	87	-2	2	7	49	45	2	8	1	44	38
1	1	3	5	12	-1	6	2	27	28	-2	2	8	2	17	2	8	2	31	28
-1	1	3	1	11	-1	6	3	75	74	-2	3	0	555	544	-2	8	2	25	24
-1	1	4	16	9	-1	6	3	46	49	2	3	0	561	544	-2	8	3	47	43
1	1	4	8	6	-1	6	4	22	25	2	3	1	57	60	2	8	3	26	28
-1	1	5	22	9	-1	6	4	8	1	-2	3	1	57	59	-2	8	4	2	10
1	1	5	2	9	-1	6	5	36	35	-2	3	2	543	525	-2	9	0	120	119

-2 9 9	120 119	-3 5 6	27 24	4 3 2	16 7	5 1 3	22 23
-2 9 1	28 28	-3 5 7	2 4	-4 3 3	1 8	-5 1 4	112 116
-2 9 1	16 16	-3 6 0	19 17	-4 3 4	27 26	5 1 4	2 8
-2 9 2	115 116	-3 6 0	16 17	4 3 4	19 23	-5 1 5	33 30
-2 9 3	26 25	-3 6 1	40 44	-4 3 6	22 16	-5 1 6	51 54
3 0 2	24 25	3 6 1	36 31	-4 3 7	15 9	-5 1 7	19 17
-3 0 2	47 59	-3 6 2	24 24	-4 3 8	21 24	-5 1 8	17 16
-3 0 4	31 30	-3 6 3	37 35	4 4 0	147 142	5 2 0	211 204
-3 0 4	10 6	3 6 3	7 14	-4 4 0	147 142	-5 2 0	212 204
-3 0 6	7 5	-3 6 4	19 23	-4 4 1	290 288	-5 2 1	84 85
-3 0 8	2 4	3 6 4	2 5	4 4 1	193 194	5 2 1	39 40
-3 1 0	149 150	-3 6 5	25 16	4 4 2	63 63	5 2 2	93 92
3 1 0	150 150	-3 6 6	20 17	-4 4 2	195 194	-5 2 2	298 289
-3 1 1	23 36	-3 7 0	105 103	-4 4 3	249 253	-5 2 3	109 108
3 1 1	14 6	3 7 0	108 103	4 4 3	80 91	5 2 3	18 12
-3 1 2	134 146	-3 7 1	88 83	-4 4 4	150 146	-5 2 4	231 223
3 1 2	72 75	3 7 1	62 59	4 4 4	17 21	5 2 4	32 33
-3 1 3	54 54	-3 7 2	116 112	-4 4 5	136 137	-5 2 5	82 80
-3 1 3	2 3	3 7 2	62 62	-4 4 6	74 70	-5 2 6	105 105
-3 1 4	68 67	-3 7 3	83 76	-4 4 7	57 54	-5 2 7	44 39
3 1 4	28 25	3 7 3	25 26	-4 4 8	27 25	-5 2 8	33 37
-3 1 5	39 34	-3 7 4	82 80	-4 5 0	43 37	-5 3 0	2 11
3 1 5	2 5	-3 7 5	47 49	4 5 0	35 37	5 3 0	9 11
-3 1 6	27 22	-3 7 6	45 40	4 5 1	102 100	-5 3 1	16 7
-3 1 7	10 13	3 8 0	142 144	-4 5 1	137 132	-5 3 2	8 13
-3 1 8	2 7	-3 8 0	143 144	-4 5 2	38 38	-5 3 3	9 9
3 2 0	288 282	-3 8 1	81 81	4 5 2	34 30	5 3 3	2 2
-3 2 0	286 282	3 8 1	61 56	-4 5 3	129 128	-5 3 4	7 11
-3 2 1	236 243	3 8 2	91 88	4 5 3	60 61	5 3 4	2 8
3 2 1	160 162	-3 8 2	154 155	-4 5 4	37 35	-5 3 7	2 3
3 2 2	114 118	-3 8 3	72 68	4 5 4	18 18	-5 3 8	2 3
-3 2 2	336 335	-3 8 4	106 107	-4 5 5	91 91	5 4 0	71 71
-3 2 3	179 185	-3 8 5	32 33	-4 5 6	33 27	-5 4 0	74 71
3 2 3	66 67	-3 9 0	8 15	-4 5 7	55 54	-5 4 1	59 60
3 2 4	26 30	3 9 0	2 15	4 6 0	35 34	5 4 1	39 41
-3 2 4	193 189	-3 9 1	30 30	-4 6 0	36 34	-5 4 2	110 112
-3 2 5	86 77	-3 9 2	2 8	-4 6 1	32 25	5 4 2	23 24
3 2 5	20 20	-3 9 3	27 25	4 6 1	30 26	-5 4 3	54 53
-3 2 6	66 65	4 0 0	527 518	-4 6 2	45 48	5 4 3	11 21
-3 2 7	25 20	-4 0 0	527 518	4 6 2	13 12	-5 4 4	96 95
-3 2 8	19 18	4 0 2	223 227	4 6 3	19 16	-5 4 5	28 26
-3 3 0	42 48	-4 0 2	667 676	-4 6 4	33 36	-5 4 6	50 49
3 3 0	37 48	-4 0 4	455 483	-4 6 5	2 0	-5 4 7	7 9
3 3 1	87 86	4 0 4	61 73	-4 6 6	20 15	-5 4 8	26 16
-3 3 1	126 123	-4 0 6	176 173	-4 6 7	2 2	-5 5 0	166 162
3 3 2	32 46	-4 0 8	53 50	-4 7 0	70 70	5 5 0	166 162
3 3 2	14 16	-4 1 0	34 21	4 7 0	70 70	5 5 1	53 54
3 3 3	37 42	4 1 0	29 21	-4 7 1	108 115	-5 5 1	99 97
-3 3 3	103 105	-4 1 1	51 42	4 7 1	77 88	-5 5 2	212 217
-3 3 4	15 16	4 1 1	10 2	-4 7 2	85 82	5 5 2	86 81
3 3 4	2 5	-4 1 2	58 48	4 7 2	44 43	-5 5 3	107 107
-2 3 5	50 54	4 1 2	2 3	-4 7 3	119 112	5 5 3	2 18
3 3 5	9 17	4 1 3	24 21	-4 7 4	67 66	-5 5 4	169 174
-3 3 6	2 1	-4 1 3	42 36	-4 7 5	78 81	-5 5 5	77 78
-3 3 7	24 20	-4 1 4	33 35	-4 7 6	37 40	-5 5 6	90 86
-3 3 8	7 2	4 1 4	2 9	4 8 0	27 25	-5 5 7	34 36
3 4 0	1 4	4 1 5	22 20	-4 8 0	17 25	5 6 0	5 0
-3 4 0	17 4	-4 1 5	8 5	-4 8 1	105 107	-5 6 0	10 0
-3 4 1	48 50	-4 1 6	14 9	4 8 1	71 74	-5 6 1	24 34
3 4 1	2 9	-4 1 7	26 23	-4 8 2	32 36	5 6 1	22 29
3 4 2	2 8	-4 1 8	11 2	-4 8 3	93 99	5 6 2	2 4
-3 4 2	11 5	4 2 0	28 3	-4 8 4	31 34	-5 6 4	16 7
-3 4 3	50 50	-4 2 0	19 3	-4 8 5	54 60	-5 6 5	25 30
-3 4 4	9 7	-4 2 1	7 9	-4 9 1	2 6	-5 6 6	2 4
3 4 4	2 6	4 2 1	14 6	-4 9 2	35 25	-5 6 7	16 20
-3 4 5	20 22	-4 2 2	28 13	-4 9 3	2 3	-5 7 0	20 21
3 4 5	17 10	4 2 2	18 6	5 0 0	71 79	5 7 0	18 21
-3 4 6	2 4	-4 2 3	13 15	-5 0 0	71 79	5 7 1	24 29
-3 4 7	14 7	4 2 3	12 3	-5 0 2	99 107	-5 7 1	43 46
-3 5 0	66 68	-4 2 4	24 25	-5 0 4	55 63	-5 7 2	25 29
3 5 0	72 68	4 2 4	2 4	5 0 4	2 10	-5 7 3	51 88
3 5 1	2 5	-4 2 5	16 15	-5 0 6	11 14	-5 7 4	30 25
-3 5 1	2 14	-4 2 6	10 16	-5 0 8	2 0	-5 7 5	26 28
-3 5 2	75 74	-4 2 7	5 10	-5 1 0	86 86	-5 7 6	22 17
3 5 2	33 34	-4 2 8	4 6	5 1 0	88 86	5 8 0	9 5
-3 5 3	2 8	-4 3 0	37 40	5 1 1	52 52	-5 8 0	2 6
3 5 3	18 5	4 3 0	40 40	-5 1 1	73 71	-5 8 1	9 3
-3 5 4	44 48	4 3 1	2 13	-5 1 2	135 138	-5 8 2	22 12
3 5 4	8 8	-4 3 1	14 20	5 1 2	39 31	-5 8 3	17 5
-3 5 5	2 2	-4 3 2	72 66	-5 1 3	58 55	-5 8 4	2 10

-6 0 0	188	186	-6 6 6	103	103	-7 5 7	29	28	-8 6 4	76	73
-6 0 0	188	186	-6 6 7	19	12	-7 6 0	17	13	-8 6 5	13	8
-6 0 2	319	305	-6 7 0	2	9	-7 6 0	2	13	-8 6 6	62	59
-6 0 2	81	78	-6 7 0	13	9	-7 6 1	65	63	-9 0 0 0	13	23
-6 0 4	290	284	-6 7 1	30	34	-7 6 2	11	14	-9 0 0 0	13	23
-6 0 6	159	156	-6 7 2	2	0	-7 6 3	91	81	-9 0 2	21	16
-6 0 8	67	63	-6 7 3	28	33	-7 6 4	2	8	-9 0 4	11	3
-6 1 0	13	18	-6 7 4	22	8	-7 6 5	73	66	-9 0 6	2	14
-6 1 0	13	18	-6 7 5	8	13	-7 6 6	4	0	-9 0 8	2	11
-6 1 1	28	36	-6 7 6	2	5	-7 7 1	76	77	-9 1 0	32	31
-6 1 1	95	98	-6 8 2	16	13	-7 7 2	99	99	-9 1 0	36	31
-6 1 2	42	45	-6 8 3	2	1	-7 7 3	95	93	-9 1 1	66	61
-6 1 2	2	3	-6 8 4	20	16	-7 7 4	103	105	-9 1 2	56	57
-6 1 3	116	119	-7 0 0	49	46	-7 7 5	81	76	-9 1 2	91	90
-6 1 3	2	0	-7 0 0	49	45	8 0 3	56	60	-9 1 4	71	76
-6 1 4	38	40	-7 0 2	59	60	-8 0 0	56	60	-9 1 5	81	79
-6 1 5	63	68	-7 0 2	25	26	-8 0 2	97	98	-9 1 6	64	67
-6 1 6	2	13	-7 0 4	48	42	-8 0 4	113	115	-9 1 7	40	40
-6 1 8	2	2	-7 0 6	2	13	-8 0 5	94	93	-9 1 8	47	42
-6 2 0	52	49	-7 0 8	11	0	-8 0 8	54	57	-9 2 0	58	52
-6 2 0	51	49	-7 1 0	61	64	-8 1 0	44	44	-9 2 0	53	53
-6 2 1	146	139	-7 1 1	59	64	-8 1 0	42	44	-9 2 1	75	77
-6 2 1	73	73	-7 1 1	27	22	-8 1 1	48	54	-9 2 1	113	107
-6 2 2	71	74	-7 1 1	8	14	-8 1 1	31	30	-9 2 3	98	97
-6 2 2	25	25	-7 1 2	105	103	-8 1 2	51	60	-9 2 4	146	142
-6 2 3	176	168	-7 1 2	24	27	-8 1 3	70	79	-9 2 5	83	85
-6 2 3	28	30	-7 1 3	34	29	-8 1 4	61	62	-9 2 6	124	119
-6 2 4	75	74	-7 1 4	95	98	-8 1 5	74	77	-9 2 7	59	52
-6 2 5	130	120	-7 1 5	39	33	-8 1 6	41	47	-9 2 8	70	66
-6 2 6	48	49	-7 1 6	53	55	-8 1 7	52	49	-9 3 1	67	66
-6 2 7	66	59	-7 1 7	29	29	-8 1 8	27	27	-9 3 2	33	33
-6 2 8	22	26	-7 1 8	22	18	8 2 0	58	53	-9 3 3	98	102
-6 3 0	164	162	-7 2 0	71	73	-8 2 0	53	53	-9 3 4	46	41
-6 3 0	170	162	-7 2 0	72	73	-8 2 1	126	124	-9 3 5	101	102
-6 3 1	32	29	-7 2 1	117	115	-8 2 1	62	65	-9 3 6	27	27
-6 3 1	55	51	-7 2 1	70	71	-8 2 2	90	89	-9 3 7	67	68
-6 3 2	228	224	-7 2 2	132	136	-8 2 3	173	174	-9 4 1	10	8
-6 3 2	94	90	-7 2 2	23	26	-8 2 4	100	99	-9 4 2	41	39
-6 3 3	57	52	-7 2 3	121	126	-8 2 5	163	163	-9 4 3	13	3
-6 3 3	7	12	-7 2 4	145	151	-8 2 5	168	163	-9 4 4	44	45
-6 3 4	202	210	-7 2 5	83	84	-8 2 6	73	68	-9 4 5	2	3
-6 3 6	133	133	-7 2 6	99	101	-8 2 7	109	107	-9 4 6	46	36
-6 3 7	17	10	-7 2 7	36	37	-8 2 8	37	34	-9 4 7	2	4
-6 3 8	71	65	-7 2 8	51	45	-8 3 0	52	54	-9 5 2	21	17
-6 4 0	80	80	-7 3 0	20	23	-8 3 0	52	54	-9 5 3	36	34
-6 4 0	80	80	-7 3 0	27	23	-8 3 1	25	26	-9 5 4	22	18
-6 4 1	94	93	-7 3 1	32	29	-8 3 1	15	20	-9 5 5	32	32
-6 4 1	52	53	-7 3 1	22	18	-8 3 2	86	91	-9 5 6	8	14
-6 4 2	101	101	-7 3 2	48	49	-8 3 3	23	22	-10 0 2	68	65
-6 4 2	48	46	-7 3 2	12	5	-8 3 4	102	105	-10 0 4	78	79
-6 4 3	110	114	-7 3 3	37	32	-8 3 5	18	12	-10 0 6	71	73
-6 4 4	91	90	-7 3 4	44	52	-8 3 6	76	77	-10 1 2	26	20
-6 4 5	90	91	-7 3 5	17	26	-8 3 7	2	6	-10 1 3	37	46
-6 4 6	63	59	-7 3 6	24	25	-8 3 8	37	38	-10 1 4	26	29
-6 4 7	55	51	-7 3 7	5	16	-8 4 0	61	61	-10 1 5	50	55
-6 4 8	33	32	-7 3 8	2	2	-8 4 0	61	61	-10 1 6	24	25
-6 5 0	36	32	-7 4 0	11	0	-8 4 1	142	140	-10 1 7	34	37
-6 5 0	34	32	-7 4 0	2	0	-8 4 2	98	95	-10 2 2	45	43
-6 5 1	137	134	-7 4 1	37	36	-8 4 3	184	187	-10 2 3	74	75
-6 5 1	93	91	-7 4 1	30	29	-8 4 4	114	108	-10 2 4	60	60
-6 5 2	48	46	-7 4 2	19	19	-8 4 5	169	168	-10 2 5	78	80
-6 5 2	24	20	-7 4 3	19	25	-8 4 6	93	88	-10 2 6	54	52
-6 5 3	149	145	-7 4 4	31	30	-8 4 7	97	104	-10 2 7	61	64
-6 5 4	56	54	-7 4 5	2	6	-8 5 0	22	17	-10 3 2	2	12
-6 5 5	111	109	-7 4 6	10	22	8 5 0	5	17	-10 3 3	2	0
-6 5 6	48	44	-7 4 7	8	2	-8 5 1	11	8	-10 3 4	20	22
-6 5 7	61	62	-7 4 8	9	10	-8 5 2	2	25	-10 3 5	2	2
-6 6 0	114	120	-7 5 0	109	107	-8 5 3	7	13	-10 3 6	13	20
-6 6 0	117	120	-7 5 0	107	107	-8 5 4	15	21	-10 3 7	2	2
-6 6 1	21	19	-7 5 1	27	25	-8 5 5	2	14	-10 4 3	60	56
-6 6 1	23	21	-7 5 1	37	39	-8 5 6	2	0	-10 4 4	14	4
-6 6 2	160	169	-7 5 2	176	172	-8 5 7	15	10	-10 4 5	61	57
-6 6 3	8	12	-7 5 4	181	178	-8 6 1	2	8	-10 4 6	28	10
-6 6 4	152	159	-7 5 5	37	40	-8 6 2	70	68	-11 0 4	18	13
-6 6 5	18	11	-7 5 6	119	116	-8 6 3	2	13	-11 0 6	12	15

CURRICULUM VITAE

Sybolt Harkema, geboren 10 december 1940 te Noordeloos (Z.H.), bezocht het Christelijk Lyceum te Zeist. Het diploma Gymnasium β behaalde hij in 1958. In hetzelfde jaar begon hij zijn studie aan de Rijksuniversiteit te Utrecht. Het candidaatsexamen (e) legde hij af in mei 1962. Het doctoraal-examen (hoofdvak: fysische chemie, bijvak: theoretische fysica) werd behaald in juli 1964. Tijdens zijn studie was hij als (co)assistent verbonden aan het Fysisch Laboratorium, het Laboratorium voor Analytische Chemie en het Laboratorium voor Algemene Chemie.

Sinds augustus 1964 is hij als wetenschappelijk medewerker verbonden aan de Technische Hogeschool Twente, waar het onderzoek beschreven in dit proefschrift werd verricht.